

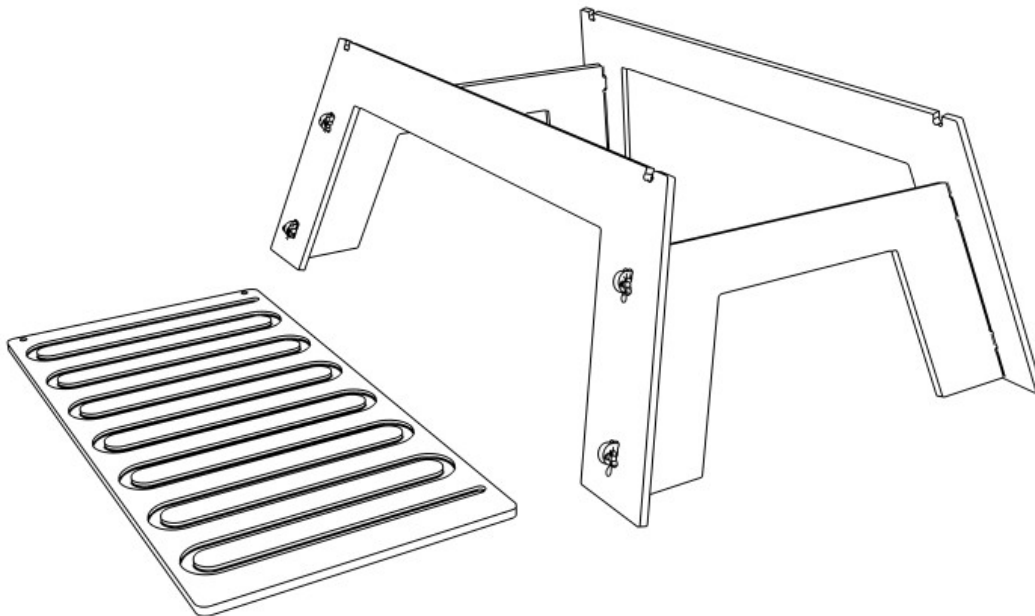

HOW TO ASSEMBLE, USE AND CARE FOR YOUR Leg Set (Small)



RECYCLED & RECYCLABLE

Products from green frog designs are made, wherever possible, from materials that are recycled. Where this is not practical, we always try to use materials that are suitable for recycling.

Our plastic is made from recycled waste plastic, predominantly plastic wrapping and carrier bags. By choosing our products, rather than those made from virgin plastic, you are helping to restrict the amount of new plastic being made. We recycle all our waste plastic and, of course, our products themselves can be recycled (if they ever wear out!!).

The recycled plastic we use is incredibly tough, but is as easily worked as wood. There is no need for preservative treatment with insecticides or fungicides, and structures won't splinter or crack, so they retain their structural integrity well. The plastic is resistant to UV light, so it retains its colour well, and is pretty much impervious to atmospheric pollutants and seasonal climatic actions such as freeze-thaw. It insulates quite well, and is also resistant to chewing. These properties mean that it retains its appearance, colour and functionality for much longer than timber.

The sheets of recycled plastic have a very uniform thickness, and so are ideally suited to our high-technology manufacturing process, which uses computer-controlled machines to cut shapes to accuracies better than 0.1mm.

We also use some metal components to fix parts together. The metals used are either stainless steel or other rust-resistant alloy, so they have a very long lifetime. They are also suitable for recycling.

Our packaging and literature is all made from recycled materials wherever possible. For example, assembly instructions are printed on recycled paper, and we use recycled plastic bubble-wrap in our packaging. Even our business cards are made from 80% recycled card.

In other words: **Fun, functional products that don't cost the Earth!**



HOW TO FIT A CLEVIS PIN (IF USED)

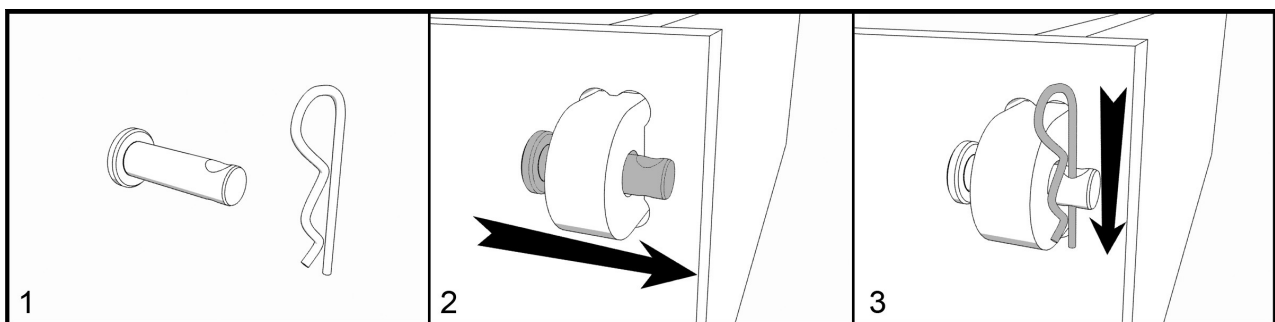

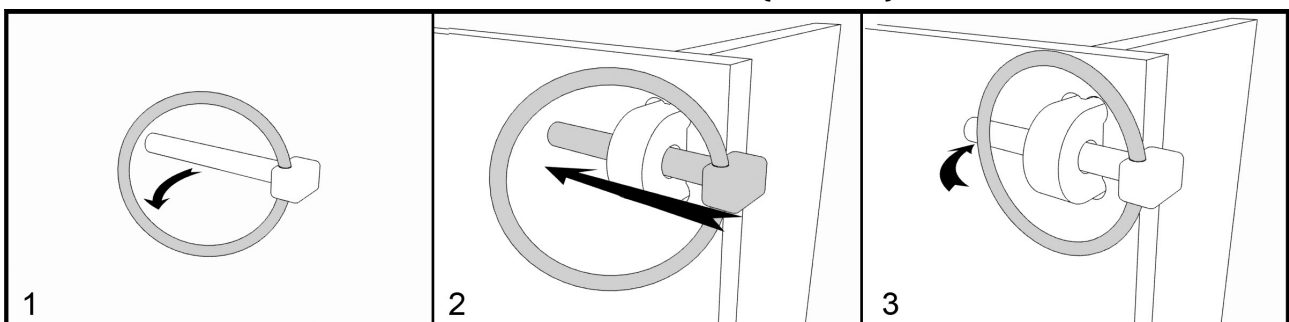

HOW TO FIT A LINCH PIN (IF USED)

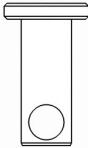
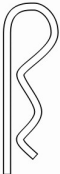

You only need to move the ring slightly away from the bar. They are designed to spring closed, so watch your fingers!

PARTS (Not to scale)

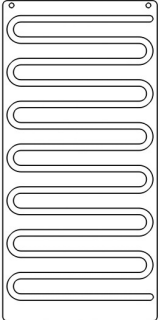
									
8x	Medium Clevis Pin	8x	R-Clip	2x	Legs A	2x	Legs B	1x	Long Ramp

DIMENSIONS

Dimensions: 81(w) x 28(h) x 51(d) cm (Excluding Ramp)

TOOLS REQUIRED

Sharp knife (e.g. Stanley Knife) or Sand Paper

PRE-ASSEMBLY CHECKS

Prior to assembly, check that you have all the required parts. Please be aware that, being a recycled material, some minor surface blemishes or defects may have occurred during manufacture. These will not affect the functionality of your product.

Trim any excess plastic using sand paper or a sharp knife. **[NOTE: Be careful to cut away from yourself.]**

If any parts are missing, please email sales@greenfrogdesigns.co.uk

Please state the part number, quantity missing, your phone number and your full postal address.

SPARE PARTS

Spare parts are available to order online via our website: www.greenfrogdesigns.co.uk

NOTE:

The **Leg Set** is not compatible with the **Run**, and cannot be used in conjunction with it. The **Leg Set** can be used with the **Wheel Set**, if required, but the **Chicken House** must be taken off the **Leg Set** before the **Wheel Set** can be used.

HOW TO ASSEMBLE

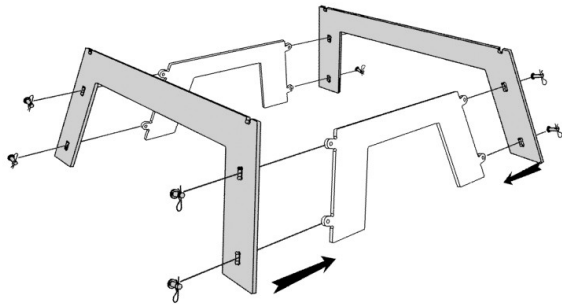

1 The **Leg Set** is assembled using 8 **Medium Clevis Pins** and **R-Clips**, as shown in the diagram above.

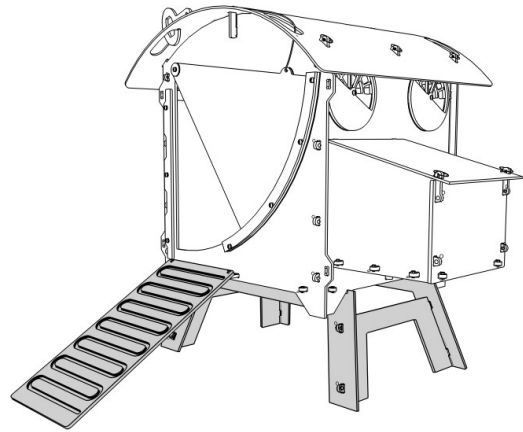

2 The **Chicken House** simply sits on the legs, with the house sides fitting into the small slots in the **Leg Set**.

The **Leg Set** comes with a longer **Ramp** which should be used to replace the standard **Ramp**.