

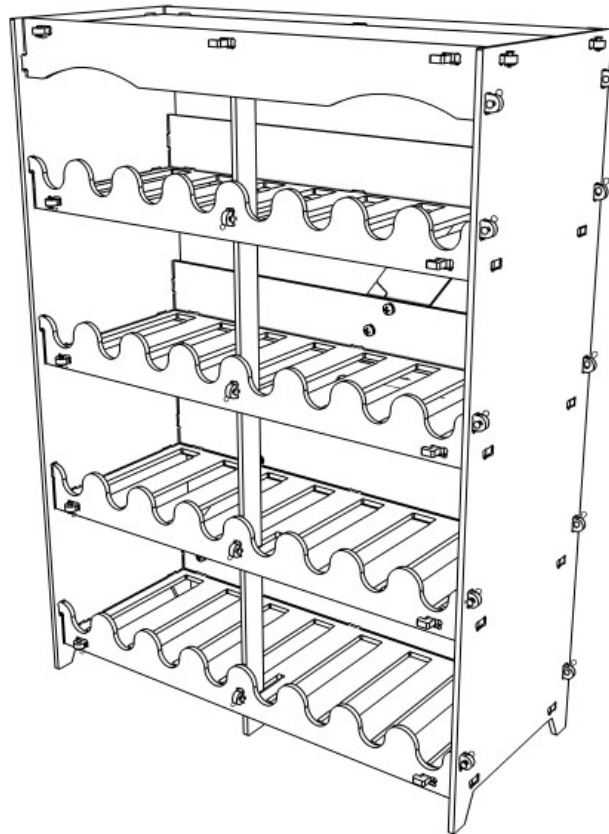

HOW TO ASSEMBLE, USE AND CARE FOR YOUR Wine Rack (Medium)



RECYCLED & RECYCLABLE

Products from green frog designs are made, wherever possible, from materials that are recycled. Where this is not practical, we always try to use materials that are suitable for recycling.

Our plastic is made from recycled waste plastic, predominantly plastic wrapping and carrier bags. By choosing our products, rather than those made from virgin plastic, you are helping to restrict the amount of new plastic being made. We recycle all our waste plastic and, of course, our products themselves can be recycled (if they ever wear out!!).

The recycled plastic we use is incredibly tough, but is as easily worked as wood. There is no need for preservative treatment with insecticides or fungicides, and structures won't splinter or crack, so they retain their structural integrity well. The plastic is resistant to UV light, so it retains its colour well, and is pretty much impervious to atmospheric pollutants and seasonal climatic actions such as freeze-thaw. It insulates quite well, and is also resistant to chewing. These properties mean that it retains its appearance, colour and functionality for much longer than timber.

The sheets of recycled plastic have a very uniform thickness, and so are ideally suited to our high-technology manufacturing process, which uses computer-controlled machines to cut shapes to accuracies better than 0.1mm.

We also use some metal components to fix parts together. The metals used are either stainless steel or other rust-resistant alloy, so they have a very long lifetime. They are also suitable for recycling.

Our packaging and literature is all made from recycled materials wherever possible. For example, assembly instructions are printed on recycled paper, and we use recycled plastic bubble-wrap in our packaging. Even our business cards are made from 80% recycled card.

In other words: **Fun, functional products that don't cost the Earth!**



HOW TO FIT A CLEVIS PIN (IF USED)

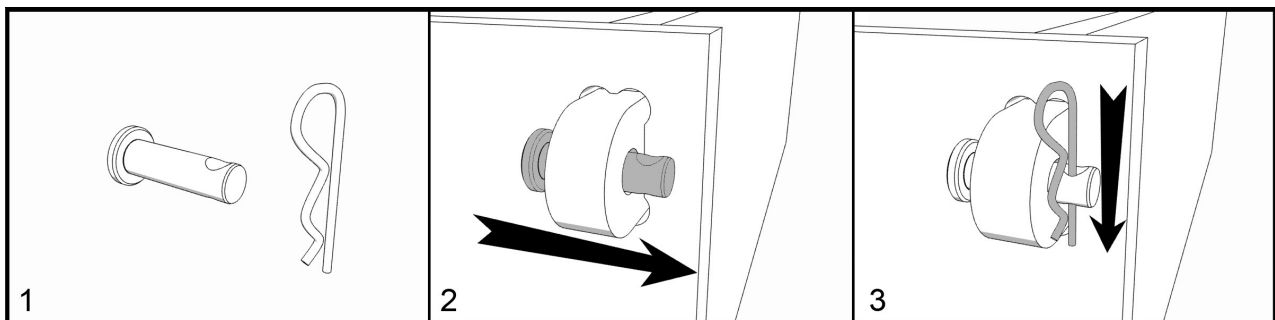



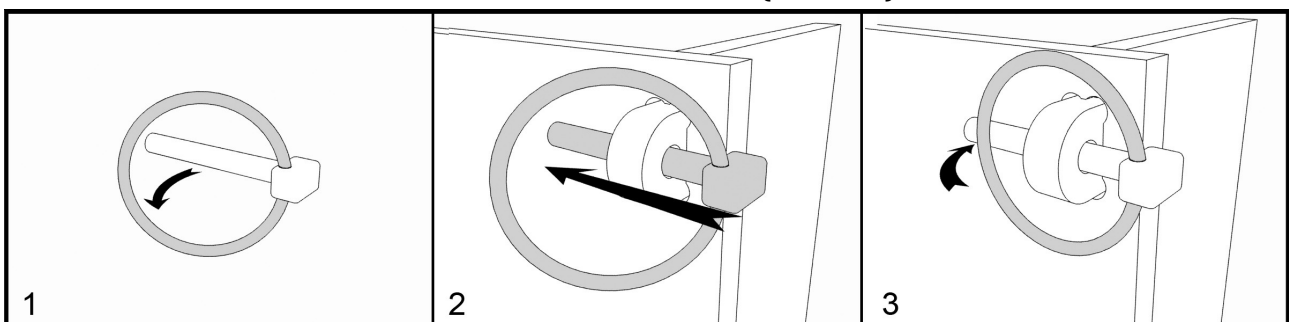





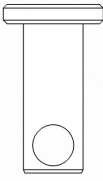
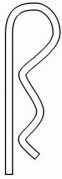
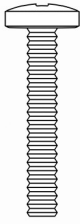

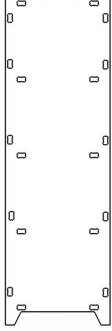

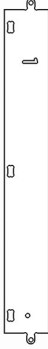

HOW TO FIT A LINCH PIN (IF USED)

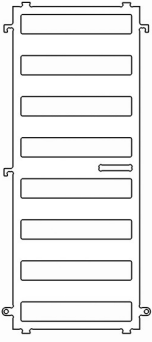

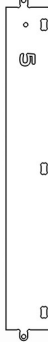
You only need to move the ring slightly away from the bar. They are designed to spring closed, so watch your fingers!

PARTS (Not to scale)

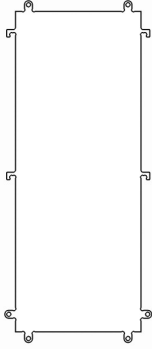
				
38x Medium Clevis Pin	38x R-Clip	6x Medium Screw	4x Bottle Rest	2x Side Panel
				
1x Brace 1	1x Brace 2	1x Shelf Back 1	1x Shelf Back 2	1x Shelf Back 3
				
1x Shelf Back 4	4x Shelf	1x Shelf Retainer	1x Top Back	6x Nylock Nut
				
6x Standard Washer	1x Top Front	1x Top		

DIMENSIONS

Dimensions: 112(w) x 98(h) x 32(d) cm

TOOLS REQUIRED

Sharp knife (e.g. Stanley Knife) or Sand Paper
Large size cross head screwdriver
10mm ring spanner (or socket wrench or adjustable spanner)
Hammer/Mallet

PRE-ASSEMBLY CHECKS

Prior to assembly, check that you have all the required parts. Please be aware that, being a recycled material, some minor surface blemishes or defects may have occurred during manufacture. These will not affect the functionality of your product.

Trim any excess plastic using sand paper or a sharp knife. **[NOTE: Be careful to cut away from yourself.]**

If any parts are missing, please email sales@greenfrogdesigns.co.uk

Please state the part number, quantity missing, your phone number and your full postal address.

SPARE PARTS

Spare parts are available to order online via our website: www.greenfrogdesigns.co.uk

HOW TO ASSEMBLE

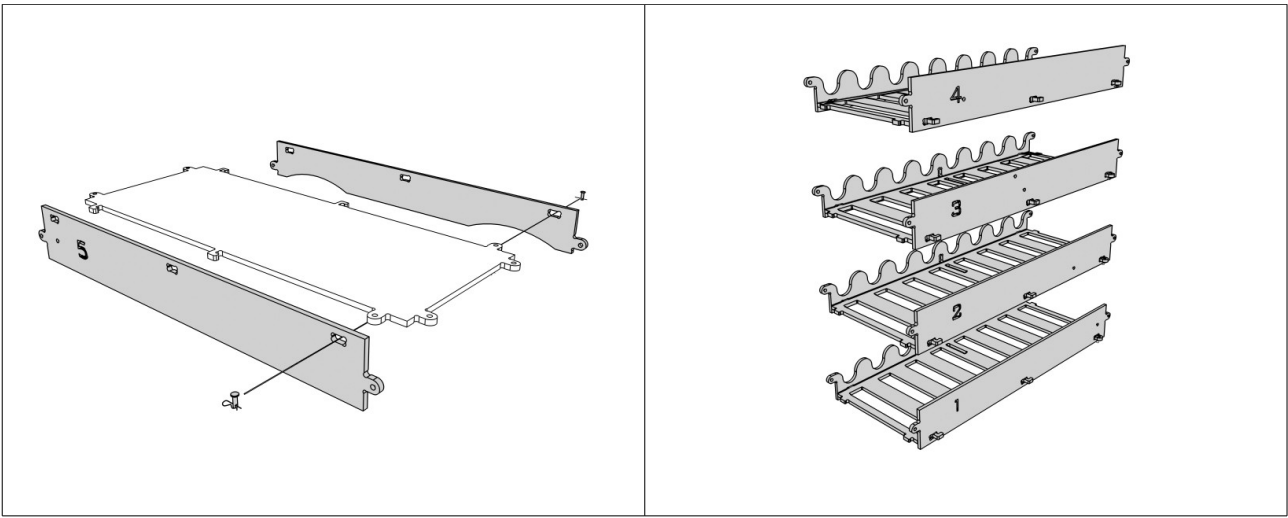

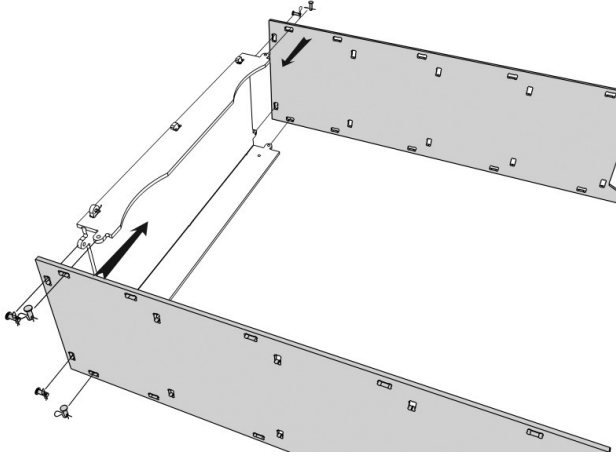
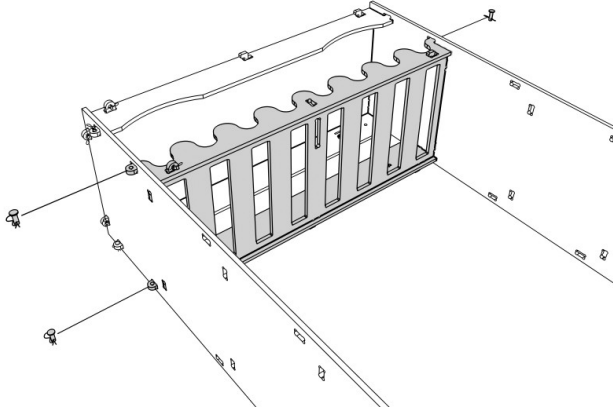
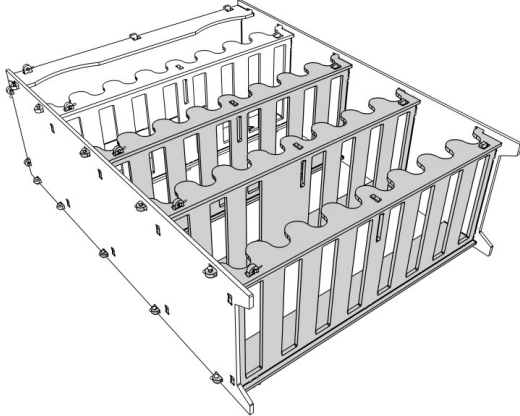
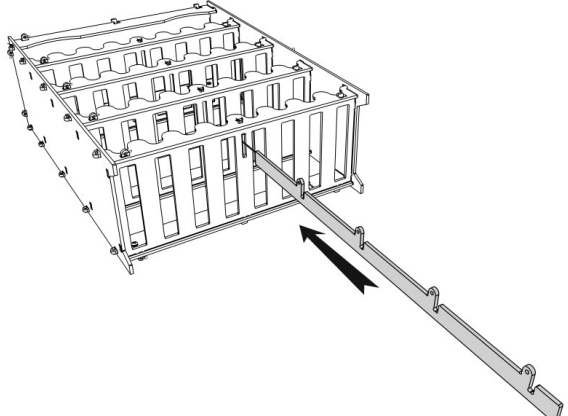
<p>1 Assemble the Top Shelf unit as shown, ensuring that the patterned sides face upwards and outwards. Fit the Top Back (Numbered 5) to the Top by aligning the holes with the L-shaped lugs and pushing home. Then slide the Top Back until the circular lug fits through the corresponding hole. You may need to tap the end of the Top Back with a hammer to get it to slide sideways. Secure it with a Clevis Pin and R-Clip. Fit the Top Front in the same way.</p>	<p>2 Assemble the Wine Shelf units the same way. Be careful to ensure that the numbered Shelf Supports are all oriented as shown in the diagram.</p>
	
<p>3 With the Top Shelf Unit, numbered 5, lying on its side, fit the Side Panels using Clevis Pins and R-Clips. Make sure that the curved edge of the Top Shelf Unit faces upwards.</p>	<p>4 Fit the Shelf Unit numbered 4 into the Side Panels. Make sure that the wavy edge is upwards and faces the curved edge of the Top Shelf Unit. You will need to push the shelf into position until the square lugs enter the holes in the sides. If necessary, tap home gently with a hammer. Secure with Clevis Pins and R-Clips on both sides.</p>
	
<p>5 In order, fit Wine Shelf Units 3, 2 and 1 in the same way.</p>	<p>6 Pass the Shelf Retainer, with lugs to the front, through the long slot in Shelf Unit 1, then 2, 3 and 4 until it touches the Top. Then pull the Shelf Retainer upwards until the lugs protrude through the Wine Shelf Front Supports, and secure them with Clevis Pins and R-Clips.</p>

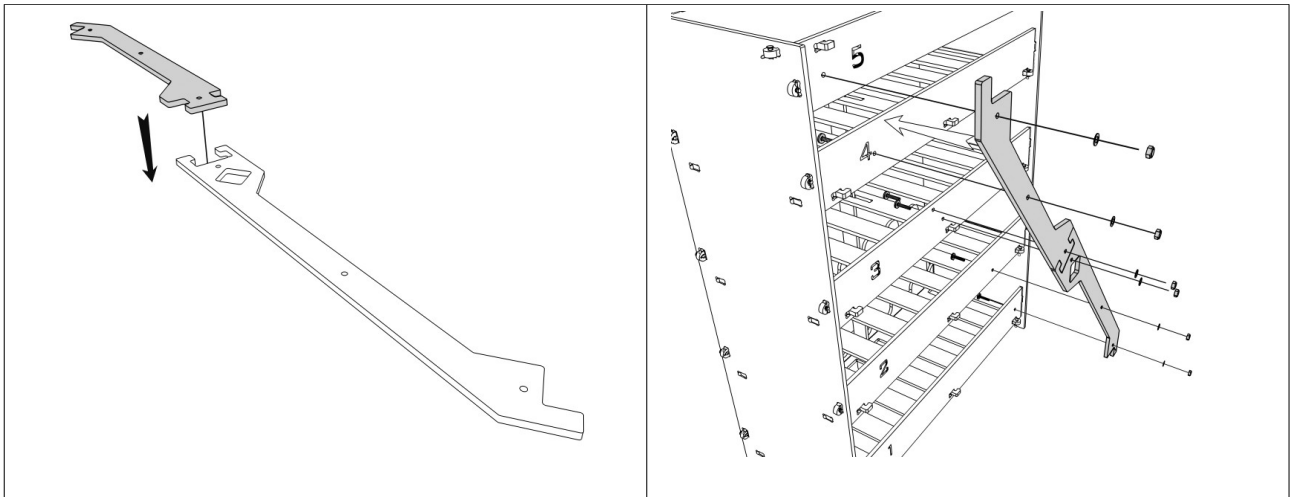

7 Rear **Braces 1** and **2** fit together just like a jigsaw. Simply position the 'male' and 'female' ends over one another, as shown in the diagram, and tap home firmly with a hammer. They are a deliberately tight fit.

8 Fit the **Brace Unit** to the **Shelf Backs** using **Screws, Washers** and **Nylock Nuts**. Ensure that the **Nylock Nuts** are all to the rear, otherwise you risk breaking a bottle on the exposed end of the screw threads.

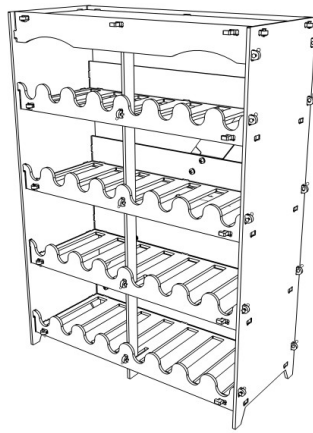

9 While the Wine Rack is very stable, a fully laden rack is extremely heavy and could be dangerous if not secured to a wall. We strongly recommend that the rack is fixed to a wall using two long screws or bolts (not provided) fixed through both ends of the **Top Back**.
You are finished. Time to fill the rack with wine. But open a bottle and have a glass first - you deserve it!

INFORMATION

Wines, reds in particular, should be stored away from the light, ideally in a cool environment (7-18 degrees Celsius, 45-65 degrees Fahrenheit). A cellar is ideal, or perhaps you have an outhouse or garage. It is best not to store wine in the main living rooms of your house, as central heating will usually mean that the temperature is too high.

Your wine rack holds the wine bottles on their sides so that the wine is in contact with the corks. This prevents the corks from drying out and helps keep air from entering the bottles and spoiling the wine. A wine spoiled in this way is often said to be 'corked'. Moist corks are also easier to extract.

Each shelf in your wine rack can be stacked up to three bottles high. However, please use your common sense. Try to keep the loads evenly spread, with the most heavily loaded shelves at the bottom.

Your wine rack should need no maintenance. It can be cleaned with soapy water and a cloth or, if very dirty, a pressure washer (Though we recommend removing the bottles first!).

SAFETY NOTE: While the Wine Rack is very stable, a fully laden rack is extremely heavy and could be dangerous if not secured to a wall. We strongly recommend that the rack is fixed to a wall using two long screws or bolts (not provided) fixed through both ends of the Top Shelf Back.