

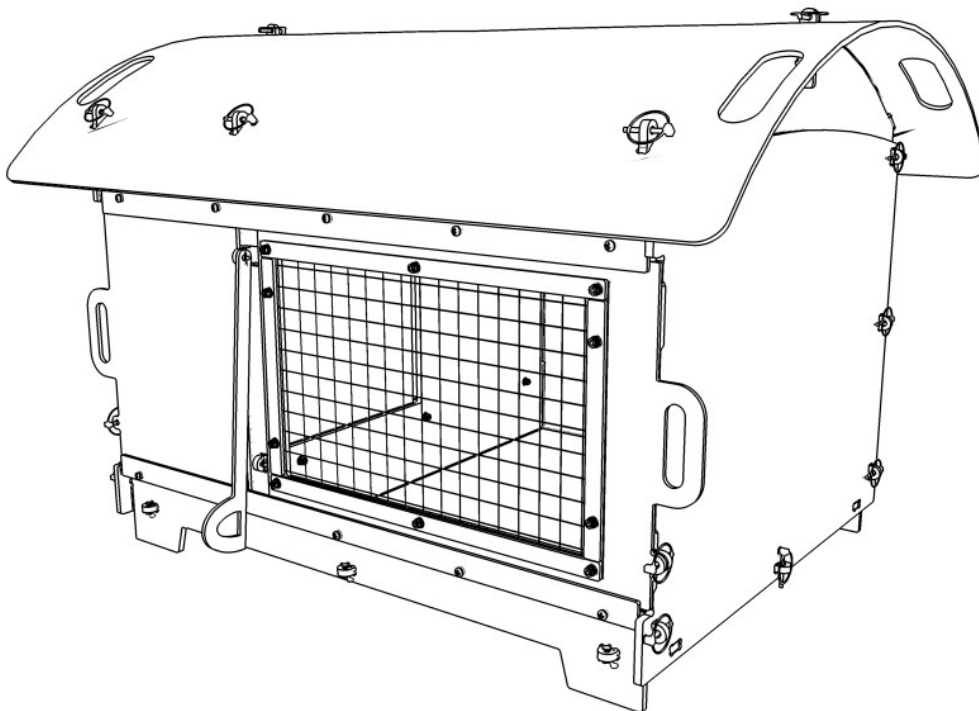

HOW TO ASSEMBLE, USE AND CARE FOR YOUR Rabbit Hutch



RECYCLED & RECYCLABLE

Products from green frog designs are made, wherever possible, from materials that are recycled. Where this is not practical, we always try to use materials that are suitable for recycling.

Our plastic is made from recycled waste plastic, predominantly plastic wrapping and carrier bags. By choosing our products, rather than those made from virgin plastic, you are helping to restrict the amount of new plastic being made. We recycle all our waste plastic and, of course, our products themselves can be recycled (if they ever wear out!!).

The recycled plastic we use is incredibly tough, but is as easily worked as wood. There is no need for preservative treatment with insecticides or fungicides, and structures won't splinter or crack, so they retain their structural integrity well. The plastic is resistant to UV light, so it retains its colour well, and is pretty much impervious to atmospheric pollutants and seasonal climatic actions such as freeze-thaw. It insulates quite well, and is also resistant to chewing. These properties mean that it retains its appearance, colour and functionality for much longer than timber.

The sheets of recycled plastic have a very uniform thickness, and so are ideally suited to our high-technology manufacturing process, which uses computer-controlled machines to cut shapes to accuracies better than 0.1mm.

We also use some metal components to fix parts together. The metals used are either stainless steel or other rust-resistant alloy, so they have a very long lifetime. They are also suitable for recycling.

Our packaging and literature is all made from recycled materials wherever possible. For example, assembly instructions are printed on recycled paper, and we use recycled plastic bubble-wrap in our packaging. Even our business cards are made from 80% recycled card.

In other words: **Fun, functional products that don't cost the Earth!**



HOW TO FIT A CLEVIS PIN (IF USED)

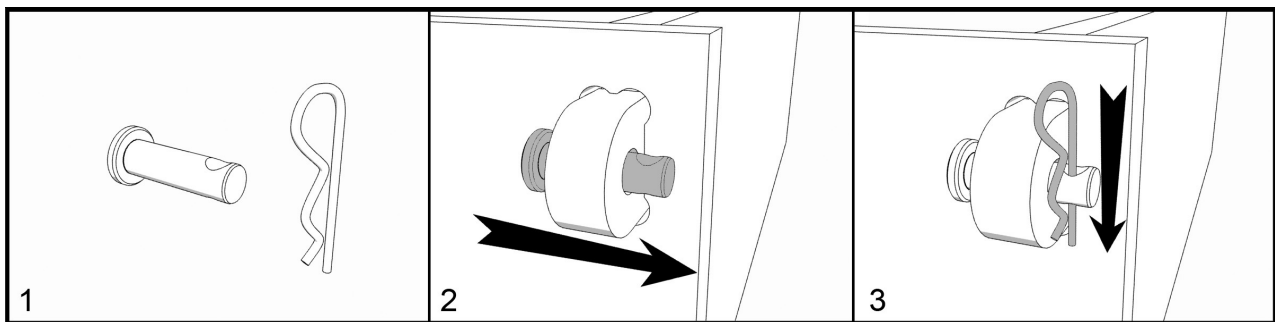



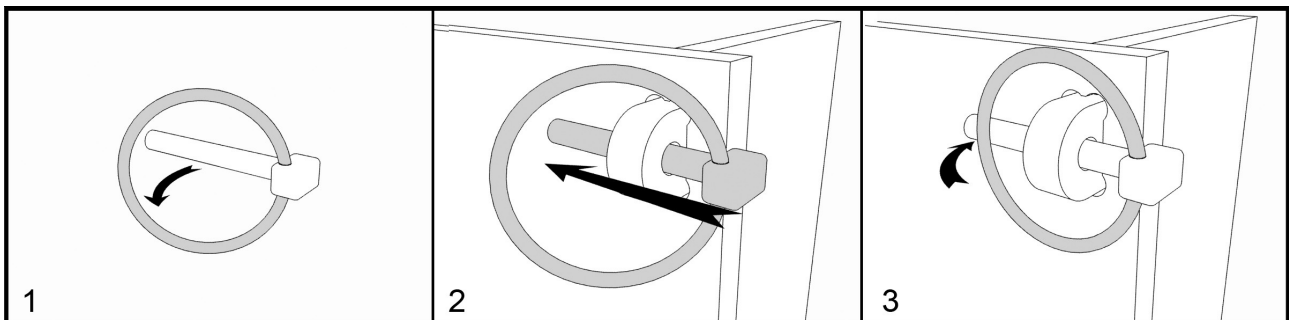





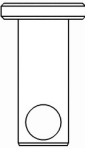

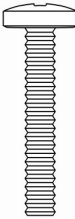
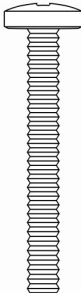

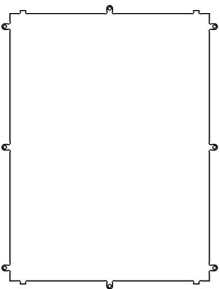

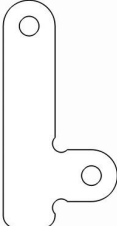
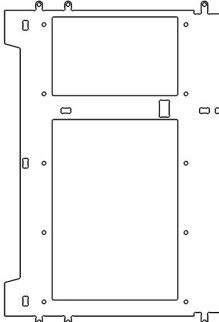
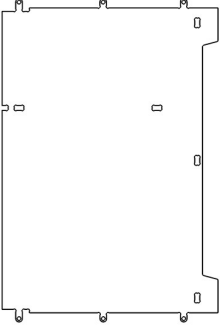
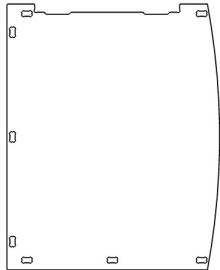
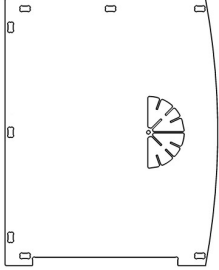
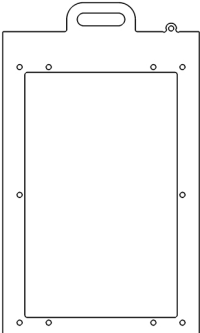
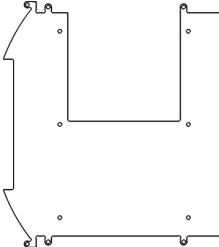
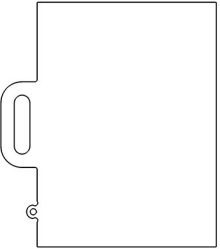
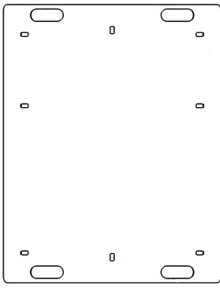
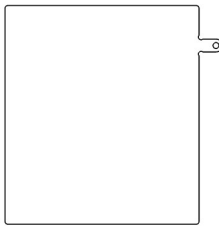

HOW TO FIT A LINCH PIN (IF USED)

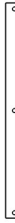

You only need to move the ring slightly away from the bar. They are designed to spring closed, so watch your fingers!

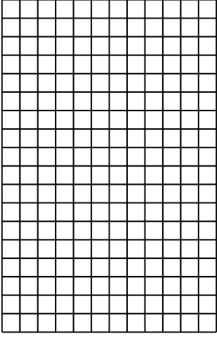
PARTS (Not to scale)

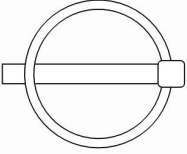
				
13x Medium Clevis Pin	13x 6mm R-Clip	10x 20mm Screw	16x 30mm Screw	26x Standard Washer
				
1x Floor	26x Nylock Nut	2x End Wall Top	2x Roof Support	1x Front Wall
				
1x Back Wall	1x Right End Wall	1x Left End Wall	1x Mesh Door	1x Centre Divide
				
1x Solid Door	1x Roof	1x Inner Door	1x Upper Long Thin Runner	2x Long Wide Runner

				
2x Short Thin Runner	2x Short Wide Runner	1x Door Pull	1x Mesh	2x Mesh Bar Long
				
2x Mesh Bar Short	22x Linch Pin	1x Lower Long Thin Runner		

DIMENSIONS

Dimensions: 100(w) x 68(h) x 83(d) cm

TOOLS REQUIRED

Sharp knife (e.g. Stanley Knife) or Sand Paper
Large size cross head screwdriver
10mm ring spanner (or socket wrench or adjustable spanner)
Small flat-bladed screwdriver (optional)

PRE-ASSEMBLY CHECKS

Prior to assembly, check that you have all the required parts. Please be aware that, being a recycled material, some minor surface blemishes or defects may have occurred during manufacture. These will not affect the functionality of your product.

Trim any excess plastic using sand paper or a sharp knife. **(NOTE: Be careful to cut away from yourself.)**

If any parts are missing, please email sales@greenfrogdesigns.co.uk

Please state the part number, quantity missing, your phone number and your full postal address.

SPARE PARTS

Spare parts are available to order online via our website: www.greenfrogdesigns.co.uk

HOW TO ASSEMBLE

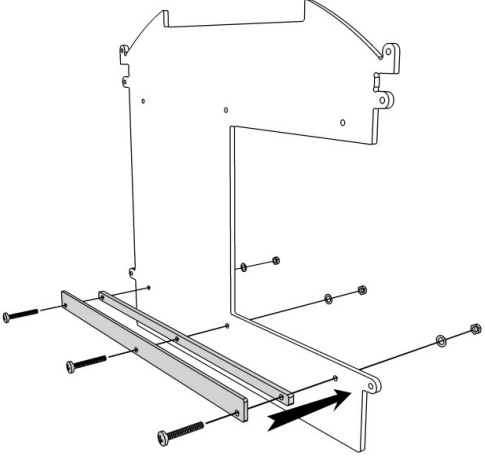
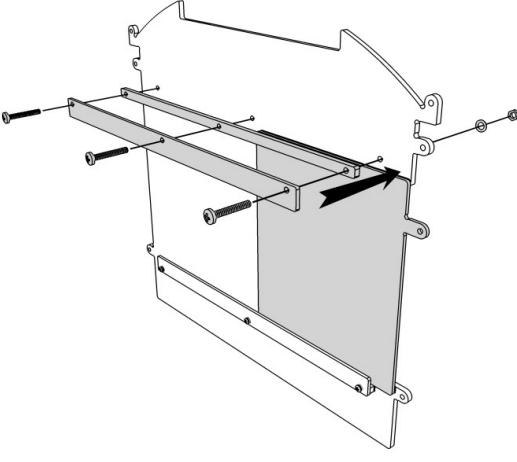
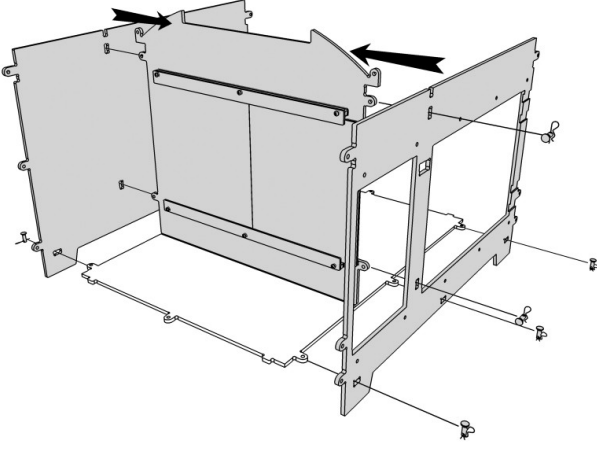
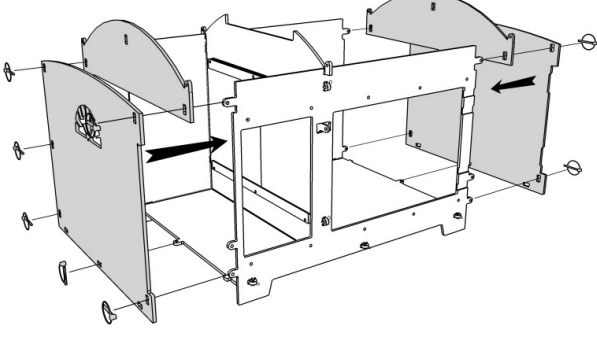
	
<p>1 Attach one Short Thin Runner (first) and one Short Wide Runner (second) below the opening on the patterned side of the Centre Divide as shown, using 40mm Screws, Washers and Nylock Nuts. The holes in the Short Wide Runner should be at the bottom, so that the two parts form a groove in which the Inner Door will run. Note: The Runners are intentionally short, to ease cleaning out the channel.</p>	<p>2 Attach the other Short Thin Runner and Short Wide Runner as before, but this time with the holes in the Short Wide Runner at the top. Then slide the Inner Door into place, ensuring that the lug is at the top.</p>
	
<p>3 Fit the Back Wall to the Floor, using Medium Clevis Pins and R-Clips. Then fit the Centre Divide and Front Wall. The Floor should have the patterned side uppermost, and the Walls patterned side outermost. The Centre Divide should be fitted so that the Inner Door is on the side facing the smaller compartment (The sleeping area).</p>	<p>4 Attach an End Wall Top at each end, and then a Left End Wall and Right End Wall using quick-release Linch Pins. Note: The cut-outs should be to the front, and the Left End Wall has the vent.</p>

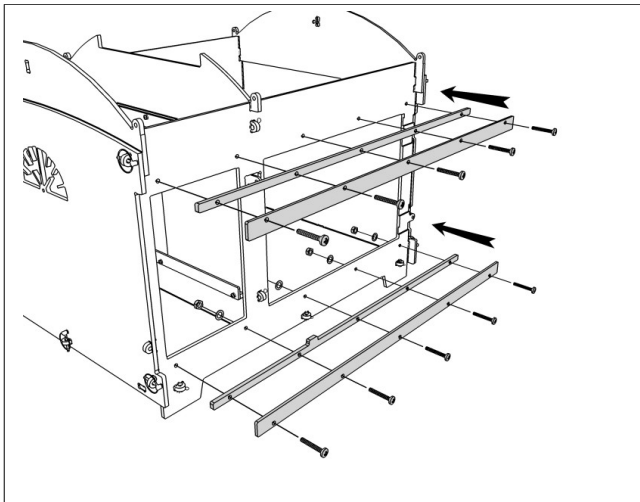

5 Attach the **Lower Long Thin Runner** and one **Long Wide Runner** to the **Front Wall**, patterned side outermost, using **30mm Screws**, **Washers** and **Nylock Nuts**. Note the position of the door stop protruding from the **Lower Long Thin Runner**. Add the **Upper Long Thin Runner** and the second **Long Wide Runner** to the top. These parts form grooves in which the front doors will run.

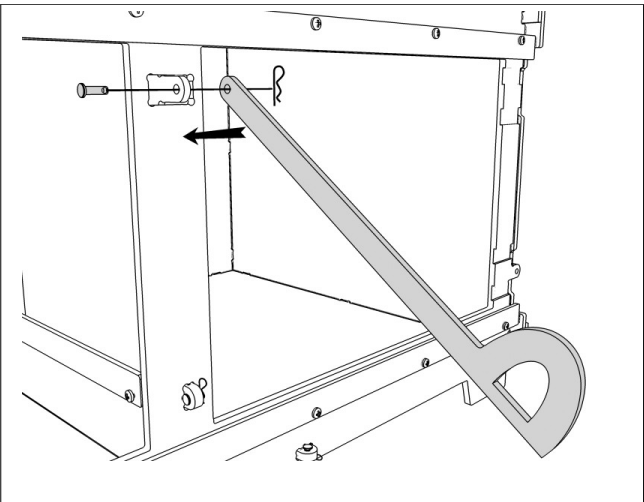

6 With the **Inner Door** in the closed position, attach the **Door Pull** to the right hand side, using a **Medium Clevis Pin** and **R-Clip**.

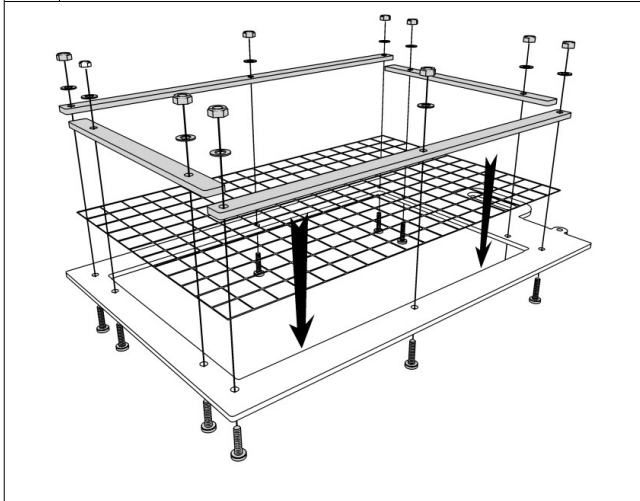

7 Sandwich the **Mesh** between the **Mesh Door** and the four **Mesh Bars**, which should have their patterned sides to the front. Secure in place using **20mm Screws**, **Washers** and **Nylock Nuts**. The **Screws** must be fitted from the rear, with the **Washers** and **Nuts** to the front.

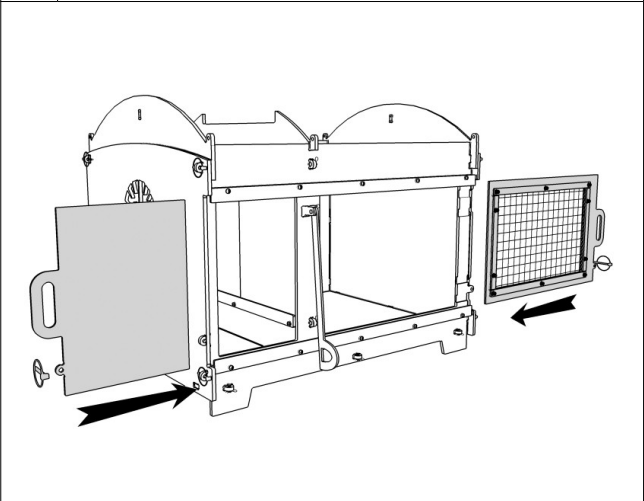

8 Slide the **Mesh Door** and the **Solid door** into place from the ends of the **Runners**. They can be locked closed using **Linch Pins**.

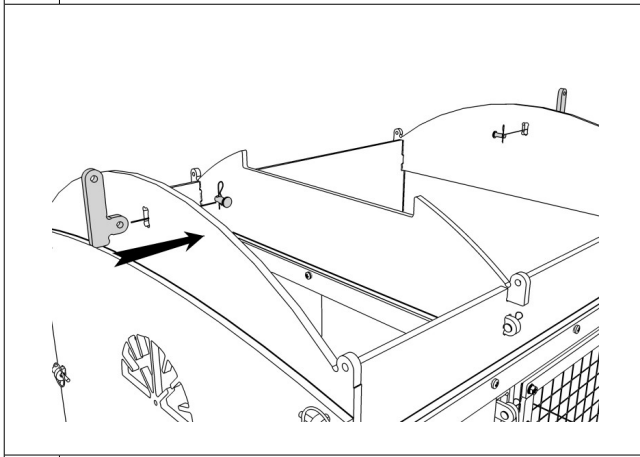

9 Fit the two **Roof Supports** and secure with **Medium Clevis Pins** and **R-Clips**

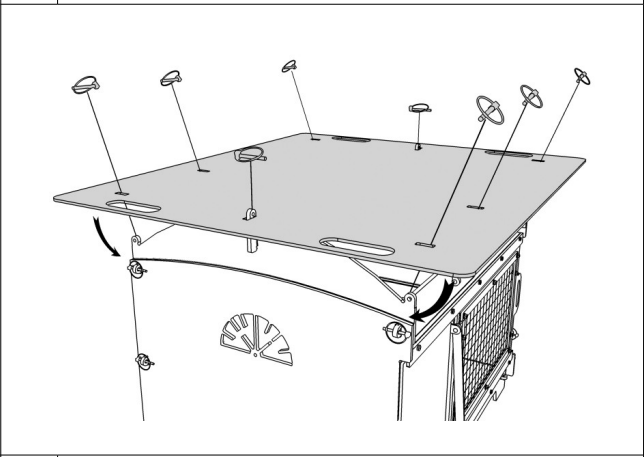

10 Fit the **Roof** using **Linch Pins**. Fix the roof to the two **Roof Supports** first, then bend it over the remaining lugs.

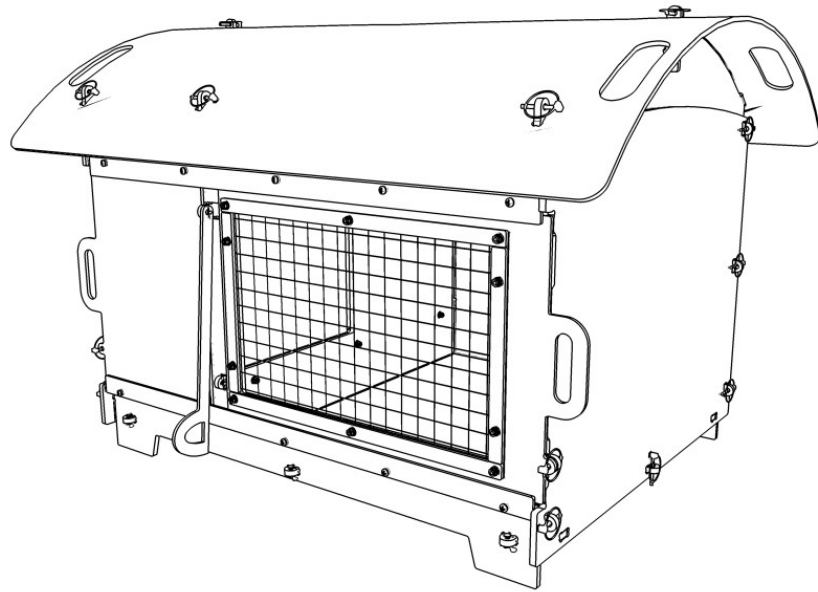

11

You're finished - Have a cup of tea!

INSTRUCTIONS FOR USE

The hutch has two compartments - a sleeping area and a living / feeding area, with a dividing door that can be easily opened and closed from the outside. Access for cleaning can be gained via full depth end panels. This detaches very simply using quick release pins. Being made of rot-proof recycled plastic, the hutch can be washed or even hosed down inside and out. The roof can also be removed for more thorough cleaning.

Even though the sides are made from black plastic, the house remains surprisingly cool, even in strong, direct summer sunlight.

There are few crevices for pests to hide in, and the house can be thoroughly cleaned very easily - in seconds if you have a pressure washer. And it will dry out very quickly, too.

Carry handles are cut into the roof, so it is easy to move. And, if you need to dismantle your rabbit hutch for any reason, perhaps because you are moving house, you can easily do so and then rebuild it just as easily. Your rabbit hutch will not be damaged by this process.

Permanent day and night access to a reasonable sized run is recommended.