

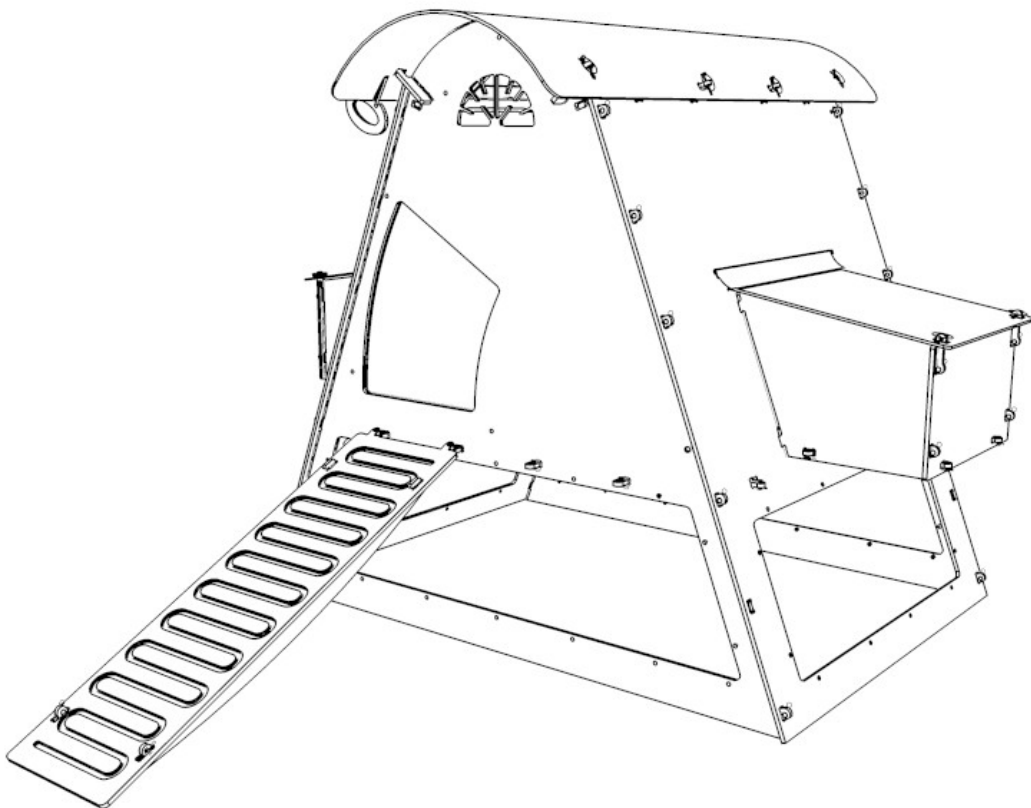

## HOW TO ASSEMBLE, USE AND CARE FOR YOUR Chicken Loft (Small)



## RECYCLED & RECYCLABLE

Products from green frog designs are made, wherever possible, from materials that are recycled. Where this is not practical, we always try to use materials that are suitable for recycling.

Our plastic is made from recycled waste plastic, predominantly plastic wrapping and carrier bags. By choosing our products, rather than those made from virgin plastic, you are helping to restrict the amount of new plastic being made. We recycle all our waste plastic and, of course, our products themselves can be recycled (if they ever wear out!!).

The recycled plastic we use is incredibly tough, but is as easily worked as wood. There is no need for preservative treatment with insecticides or fungicides, and structures won't splinter or crack, so they retain their structural integrity well. The plastic is resistant to UV light, so it retains its colour well, and is pretty much impervious to atmospheric pollutants and seasonal climatic actions such as freeze-thaw. It insulates quite well, and is also resistant to chewing. These properties mean that it retains its appearance, colour and functionality for much longer than timber.

The sheets of recycled plastic have a very uniform thickness, and so are ideally suited to our high-technology manufacturing process, which uses computer-controlled machines to cut shapes to accuracies better than 0.1mm.

We also use some metal components to fix parts together. The metals used are either stainless steel or other rust-resistant alloy, so they have a very long lifetime. They are also suitable for recycling.

Our packaging and literature is all made from recycled materials wherever possible. For example, assembly instructions are printed on recycled paper, and we use recycled plastic bubble-wrap in our packaging. Even our business cards are made from 80% recycled card.

In other words: **Fun, functional products that don't cost the Earth!**



### HOW TO FIT A CLEVIS PIN (WHERE USED)

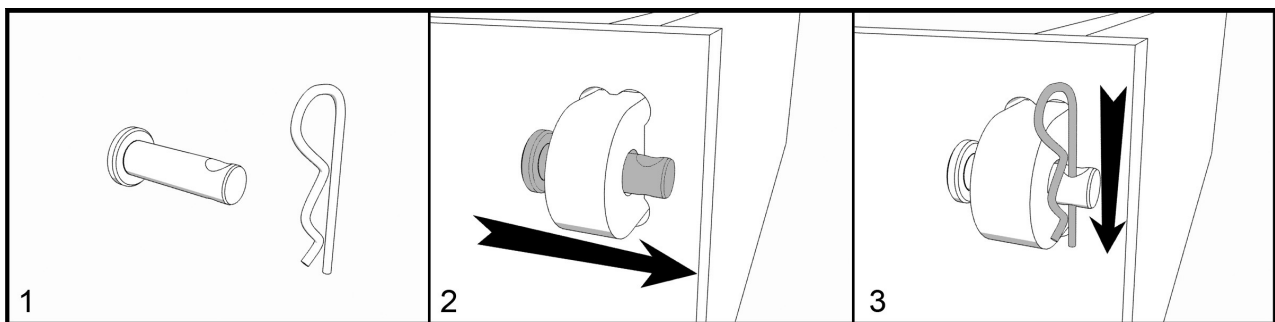



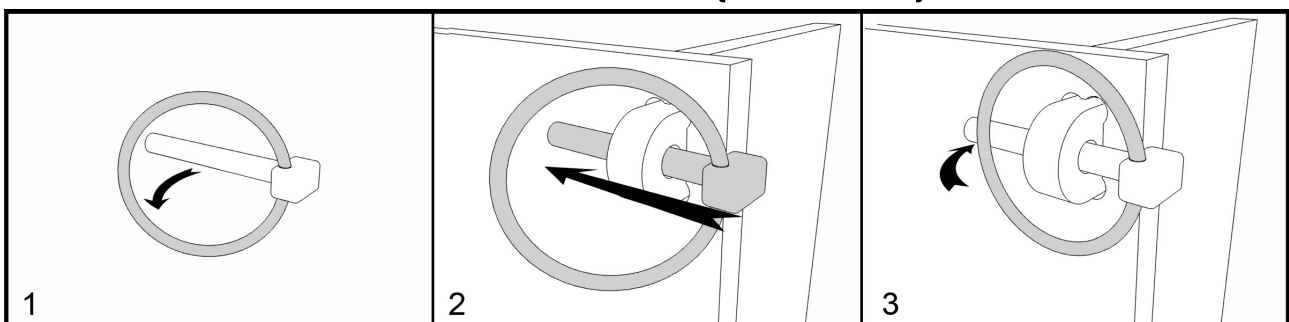





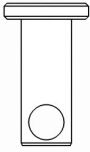

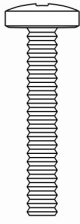
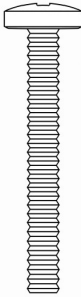

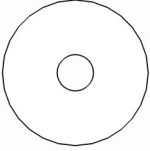

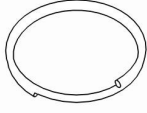
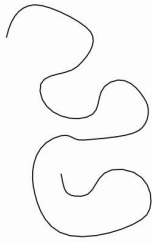

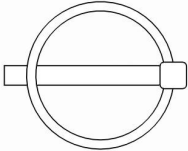
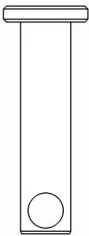
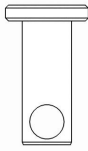
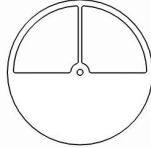
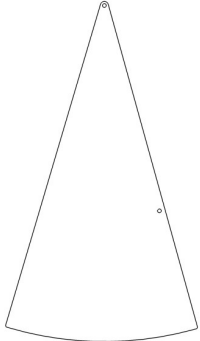

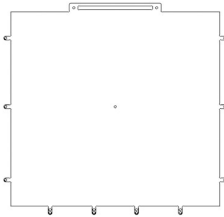

### HOW TO FIT A LINC PIN (WHERE USED)

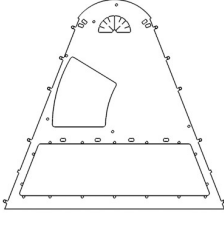
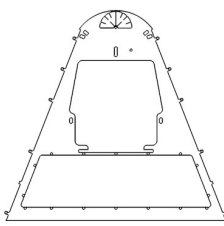
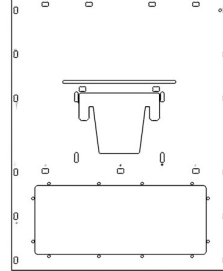
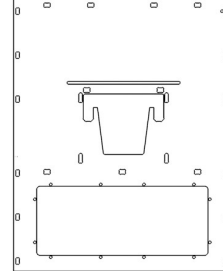

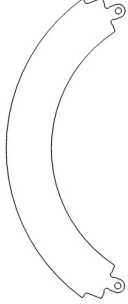
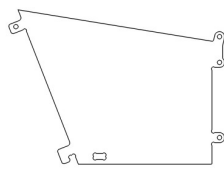
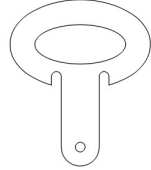
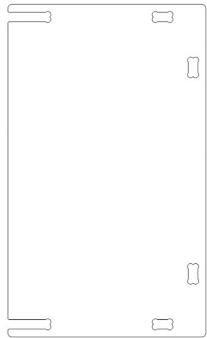
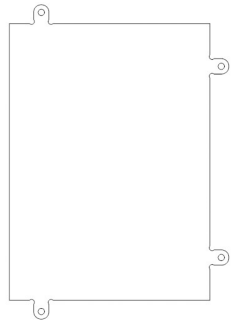
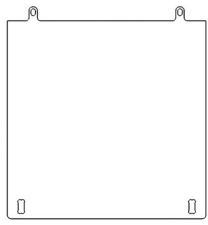
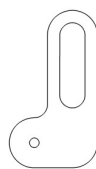
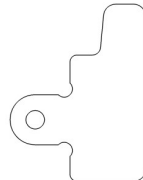
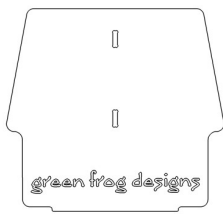
You only need to move the ring slightly away from the bar. They are designed to spring closed, so watch your fingers!

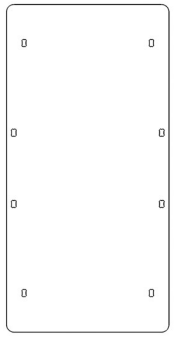
**PARTS (Not to scale)**

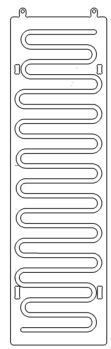
				
<b>60x</b> Medium Clevis Pin	<b>67x</b> 6mm R-Clip	<b>3x</b> 30mm Screw	<b>12x</b> 40mm Screw	<b>16x</b> Standard Washer
				
<b>3x</b> 25mm washer	<b>15x</b> Nylock Nut	<b>1x</b> Split Ring	<b>1x</b> Door Cord	<b>2x</b> Perch
				
<b>24x</b> Linch Pin	<b>6x</b> Long Clevis Pin	<b>1x</b> Short Clevis Pin	<b>1x</b> Vent Cover	<b>1x</b> Front Door
				
<b>1x</b> Long Door Retainer 1	<b>1x</b> Long Door Retainer 2	<b>1x</b> Curve Bar	<b>2x</b> Spacer	<b>1x</b> Base

									
<b>1x</b>	Front Wall	<b>1x</b>	Back Wall	<b>1x</b>	Left Side Wall	<b>1x</b>	Right Side Wall	<b>2x</b>	Roof Brace
									
<b>1x</b>	Roof Arch	<b>4x</b>	Nest Box Sides (Mirrored pairs)	<b>1x</b>	Door Handle	<b>2x</b>	Nest Box Front	<b>2x</b>	Nest Box Base
									
<b>2x</b>	Nest Box Roof	<b>1x</b>	Door Lock	<b>2x</b>	Door Retainer	<b>1x</b>	Back Door	<b>1x</b>	Back Door Handle
									
<b>1x</b>	Roof	<b>2x</b>	Ramp Brace	<b>1x</b>	Ramp	<b>2x</b>	Weather Seal (Short)	<b>2x</b>	Large Roof Bracket

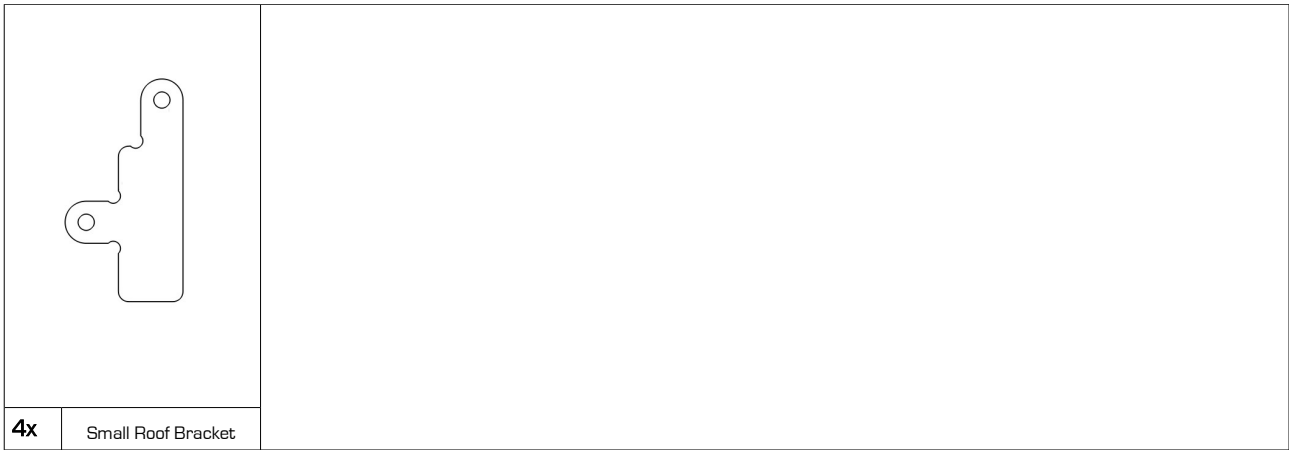

## DIMENSIONS

Dimensions: External 124(w) x 118(h) x 90(d) cm (excluding ramp and nestboxes)  
 Accommodation Size (max): 91(w) x 77(h) x 85(d) cm (excluding nest boxes)  
 Perch Length: 3 x 69 cm

## TOOLS REQUIRED

Sharp knife (e.g. Stanley Knife) or Sand Paper  
 Large size cross head screwdriver  
 10mm ring spanner (or socket wrench or adjustable spanner)  
 Small flat-bladed screwdriver (optional)

## PRE-ASSEMBLY CHECKS

Prior to assembly, check that you have all the required parts. Please be aware that, being a recycled material, some minor surface blemishes or defects may have occurred during manufacture. These will not affect the functionality of your product.

Trim any excess plastic using sand paper or a sharp knife. **(NOTE: Be careful to cut away from yourself.)**

If any parts are missing, please email [sales@greenfrogdesigns.co.uk](mailto:sales@greenfrogdesigns.co.uk)

Please state the part number, quantity missing, your phone number and your full postal address.

## SPARE PARTS

Spare parts are available to order online via our website: [www.greenfrogdesigns.co.uk](http://www.greenfrogdesigns.co.uk)

## IMPORTANT NOTE

**Due to the size and weight of the Chicken Loft, we recommend that it is built on site.**

If it needs to be moved, carry weight can be reduced by temporary removal of the Nest Boxes and Roofs, and the Roof Panel.

## HOW TO ASSEMBLE

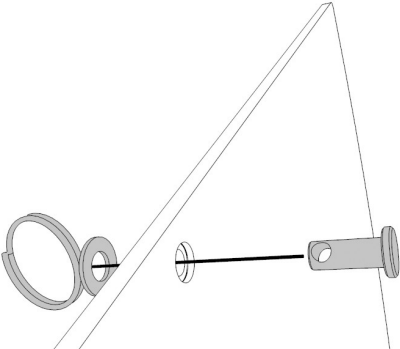
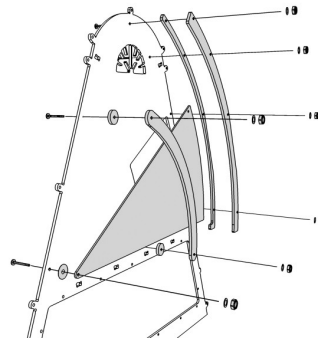
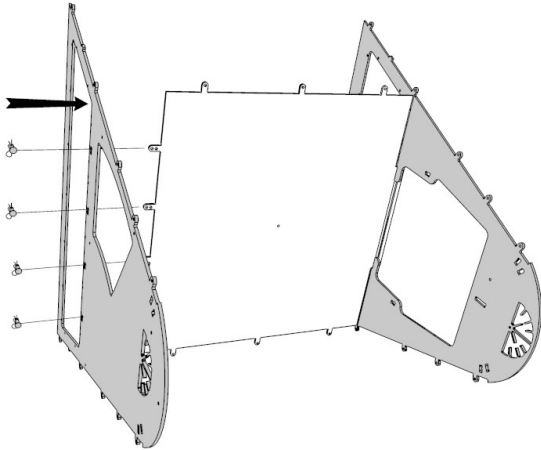
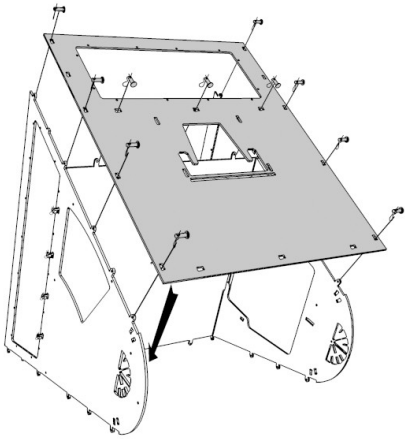
	
<p><b>1</b> Fit the <b>Small Clevis Pin</b> into the recessed hole in the <b>Front Door</b>, and secure it using a <b>Standard Washer</b> and <b>Split Ring</b>. The <b>Split Ring</b> must be on the back (the shiny side).</p> <p>Fitting can be a little awkward - we find that holding the split ring open by inserting a flat-bladed screwdriver between the rings can make this task easier. But please mind your fingers!</p> <p>Tie one end of the <b>Door Cord</b> to the <b>Split Ring</b>.</p>	<p><b>2</b> Fit the <b>Long Door Retainers</b> to the inside (shiny side) of the <b>Front Wall</b> using <b>M6x40mm Screws</b>, <b>Standard Washers</b>, and <b>Nylock Nuts</b>. Ensure the smaller piece is in the middle.</p> <p>Place the <b>Front Door</b> in position and secure it with a <b>M6x30mm Screw</b>, a <b>Standard Washer</b>, a <b>25mm Washer</b> and a <b>Nylock Nut</b>. Tighten until the door can just rotate freely.</p> <p>Fit the <b>Curve Bar</b> and <b>Spacers</b> using <b>M6x40mm Screws</b>, <b>Standard Washers</b>, and <b>Nylock Nuts</b>.</p>
	
<p><b>3</b> With the panels positioned as shown, attach the <b>Back Wall</b> and then the <b>Front Wall</b> to the <b>Base</b> using <b>Medium Clevis Pins</b> and <b>R-Clips</b>. Both walls should have the patterned side outermost.</p>	<p><b>4</b> Attach the <b>Left Side Wall</b> (pattern outermost) using <b>Clevis Pins</b> and <b>R-Clips</b>.</p> <p>Carefully turn the assembly over, and repeat for the <b>Right Side Wall</b>.</p> <p>Then turn the Loft back onto its base so that it is standing upright.</p>

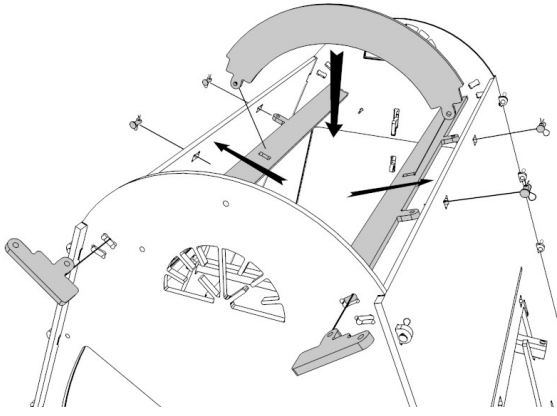
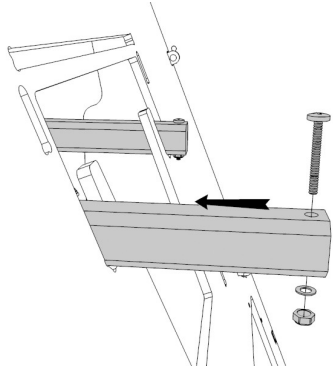
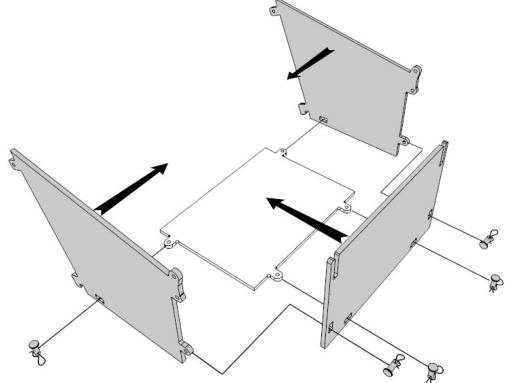
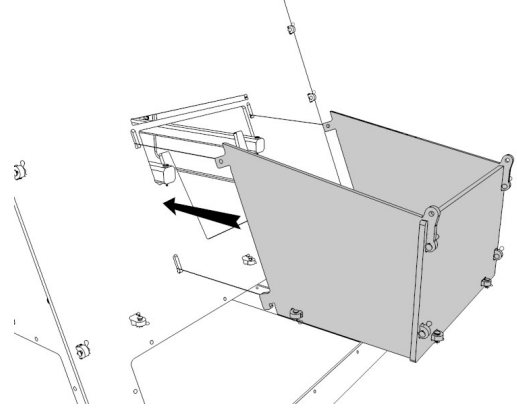
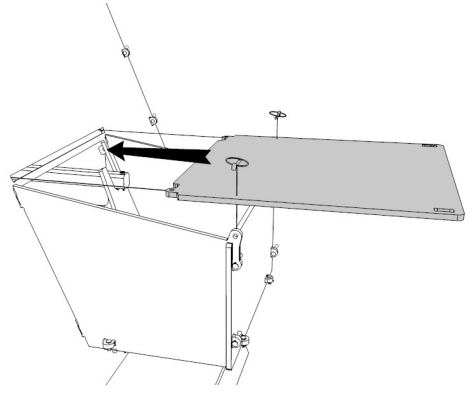
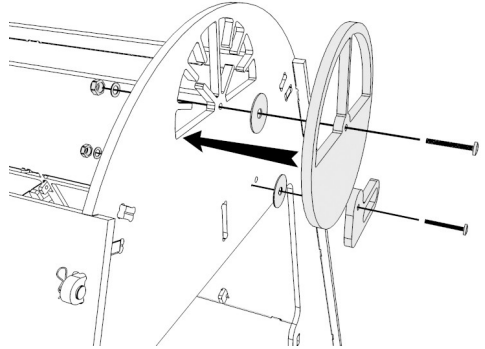
	
<p><b>5</b> Attach the <b>Roof Braces</b> and <b>Small Roof Brackets</b> using <b>Clevis Pins</b> and <b>R-Clips</b>. Use <b>Long Clevis Pins</b> for the two middle lugs on each brace. Start at one end and bend the bar to fit the other end tab – some force is required. Fit the <b>Roof Arch</b> using <b>Clevis Pins</b> and <b>R-Clips</b>.</p>	<p><b>6</b> Fit a <b>40mm Screw</b> to each end of the 2 <b>Perches</b> and secure with a <b>Standard Washer</b> and <b>Locknut</b>. Place the perches in the perch rests.</p>
	
<p><b>7</b> Fit the Nest Box using <b>Clevis Pins</b> and <b>R-Clips</b>. Fit the <b>Nest Box Sides</b> to the <b>Nest Box Base</b> first, then the <b>Nest Box Front</b> (all with pattern outermost).</p>	<p><b>8</b> Fit the nest box to the house by first inserting the L-lugs into the lower holes on the <b>Side Wall</b>, then tilting the nest box to push the upper lugs through their holes, before securing them inside the main house with <b>Linch Pins</b> (not shown).</p>
	
<p><b>9</b> Fit the <b>Nest Box Roof</b> by pushing its lugs through the holes in the <b>Side Wall</b> and secure it with <b>Linch Pins</b> inside the main house. Two more <b>Linch Pins</b> are used outside – these can be quickly removed for daily access to the nest box. Repeat steps <b>7</b> to <b>9</b> for the other nest box.</p>	<p><b>10</b> Fit the <b>Vent Cover</b> to the <b>Back Wall</b> using an <b>M6x30mm screw</b>, a <b>standard washer</b>, a <b>25mm washer</b> and a <b>Nylock nut</b>. Tighten the nut until the vent can rotate using gentle pressure. It should not spin freely. Fit the <b>Door Lock</b> using an <b>M6x30mm screw</b>, a <b>standard washer</b>, a <b>25mm washer</b> and a <b>Nylock nut</b>.</p>

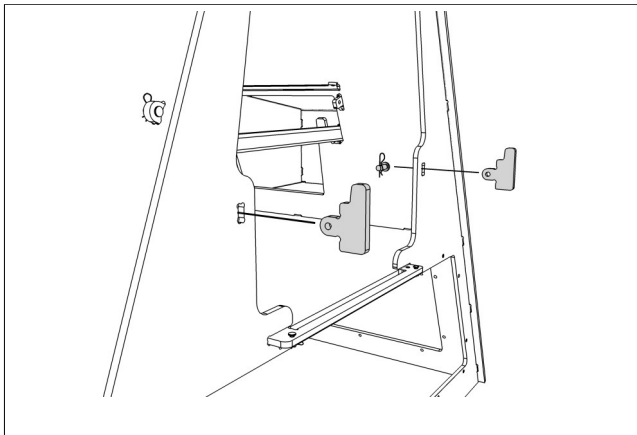

**11** Fit the **Door Retainers** to the **Back Wall** using Clevis Pins and R-Clips.

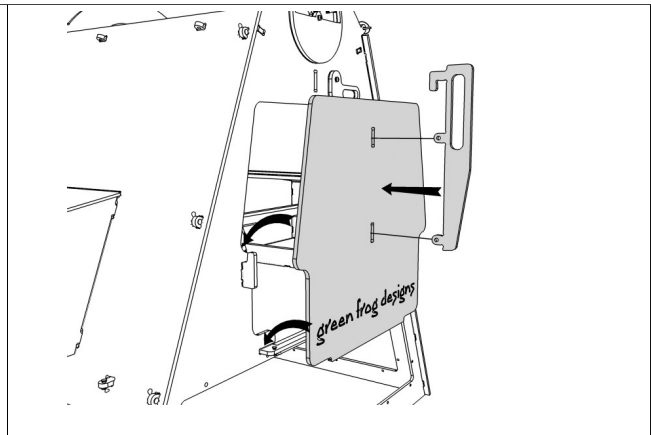

**12** Fit the **Back Door Handle** to the **Back Door** using **Medium Clevis Pins** and **R-Clips**. Fit the **Rear Door** by lowering the bottom of the door into the slots in the **Base** ensuring that the door slides down behind the **Door Retainers**. Slide the **Back Door Handle** downwards to hold the door in position. Secure it by rotating the **Door Lock**.

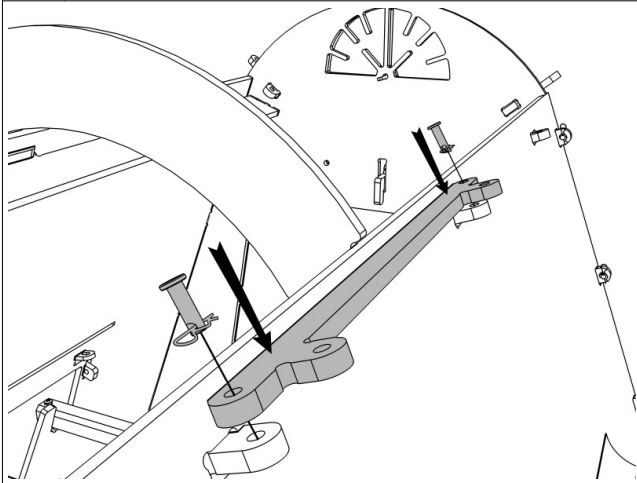

**13** Attach the two **Large Roof Brackets** above the centre two lugs on the **Roof Braces** using the **Long Clevis Pins** and **R-Clips** already in place.

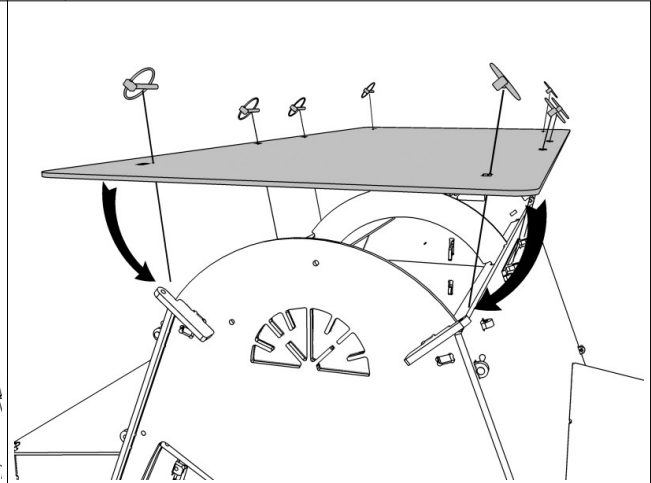

**14** Fit the **Roof** using **Linch Pins**. Fix the centre first, then bend the sides down over the remaining lugs. Do the ends first, followed by the middle. Some force may be required when the roof is fitted for the first time.

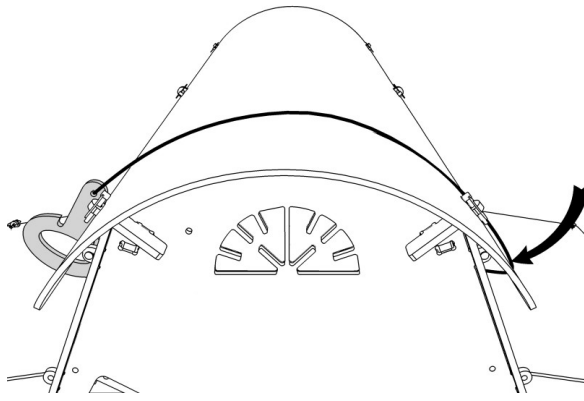

**15** Pass the end of the **Door Cord** through the hole in the top of the **Right Side Wall** before tying it to the small hole in the **Door Handle**. The **Cord** length should be adjusted so that, when the door is fully raised, the slot in the handle just hooks onto the far edge of the roof.

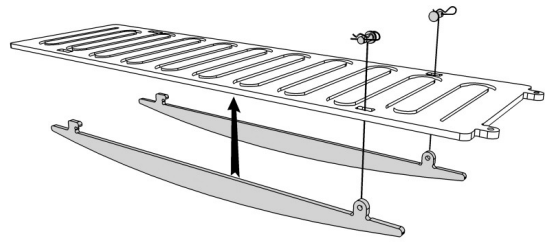

**16** Attach the **Ramp Braces** to the **Ramp** using two **Medium Clevis Pins** and **R-Clips**.

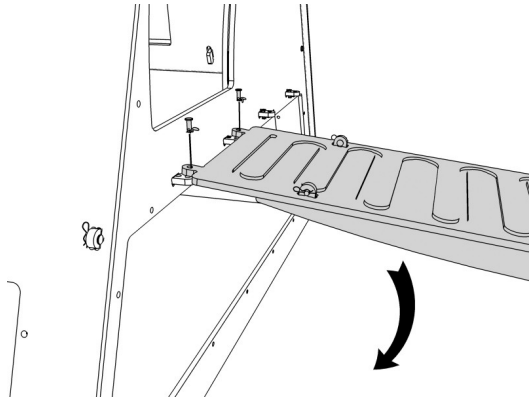

**17** Fit the **Ramp** in front of the doorway using the two **Long Clevis Pins** and **R-Clips**. Lift it to fit, and then allow it to tilt to the ground under its own weight.

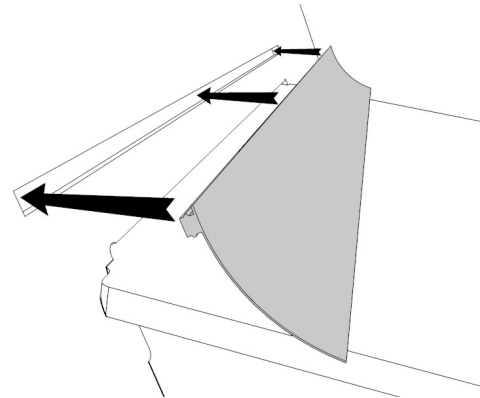

**18** Push the **Weather Seals** fully home into the slots above the **Nest Boxes** (Note: you may need to trim them to the correct length first). Start at one end and work your way along, pushing firmly. It may help to lubricate with a little washing-up liquid.

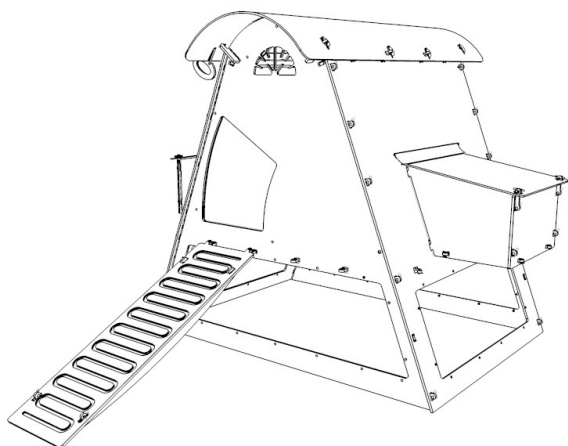

**19** You're finished - Time for a cup of tea!

## INSTRUCTIONS FOR USE

The Loft should be sited in a sheltered area with the front facing away from prevailing winds. The Vent should be adjusted to provide adequate ventilation.

Your chickens are likely to shelter under the Loft. Added protection can be provided by fitting metal mesh panels into the cutouts low on the sides and ends using cable ties (mesh and ties are not included).

The rear door provides access for inspection, for replacing of shavings/straw and regular cleaning. For thorough cleaning, the entire roof and nest boxes can be removed. We recommend thorough cleaning at least every 3 months – a pressure washer is ideal for removal of caked on dirt, but an ordinary hosepipe and scrubbing brush will do. The plastic is quite easy to clean. Finish by applying Poultry Shield (or similar) and leave to dry.