

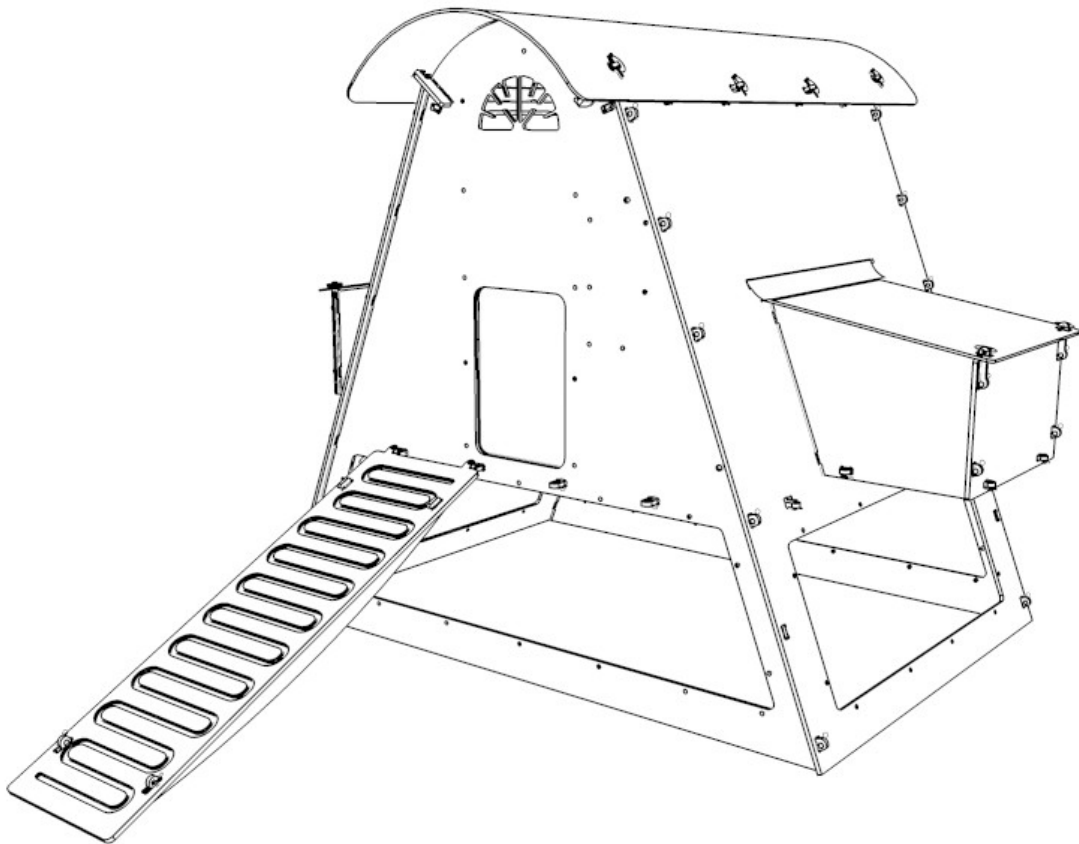

HOW TO ASSEMBLE, USE AND CARE FOR YOUR Chicken Loft VSB (Small)



RECYCLED & RECYCLABLE

Products from green frog designs are made, wherever possible, from materials that are recycled. Where this is not practical, we always try to use materials that are suitable for recycling.

Our plastic is made from recycled waste plastic, predominantly plastic wrapping and carrier bags. By choosing our products, rather than those made from virgin plastic, you are helping to restrict the amount of new plastic being made. We recycle all our waste plastic and, of course, our products themselves can be recycled (if they ever wear out!!).

The recycled plastic we use is incredibly tough, but is as easily worked as wood. There is no need for preservative treatment with insecticides or fungicides, and structures won't splinter or crack, so they retain their structural integrity well. The plastic is resistant to UV light, so it retains its colour well, and is pretty much impervious to atmospheric pollutants and seasonal climatic actions such as freeze-thaw. It insulates quite well, and is also resistant to chewing. These properties mean that it retains its appearance, colour and functionality for much longer than timber.

The sheets of recycled plastic have a very uniform thickness, and so are ideally suited to our high-technology manufacturing process, which uses computer-controlled machines to cut shapes to accuracies better than 0.1mm.

We also use some metal components to fix parts together. The metals used are either stainless steel or other rust-resistant alloy, so they have a very long lifetime. They are also suitable for recycling.

Our packaging and literature is all made from recycled materials wherever possible. For example, assembly instructions are printed on recycled paper, and we use recycled plastic bubble-wrap in our packaging. Even our business cards are made from 80% recycled card.

In other words: **Fun, functional products that don't cost the Earth!**



HOW TO FIT A CLEVIS PIN (WHERE USED)

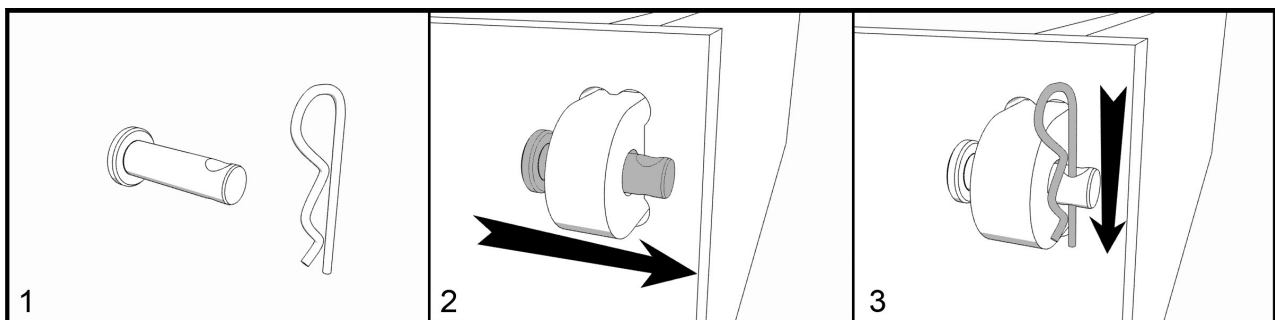



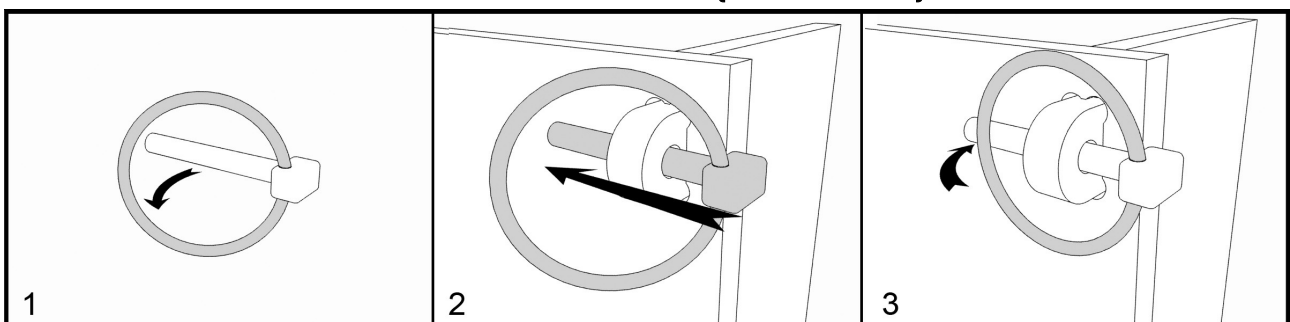





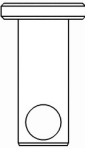

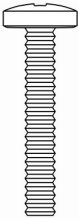
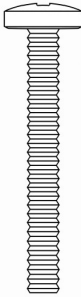

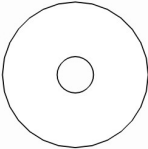

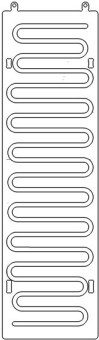

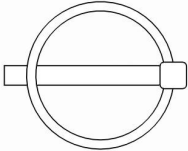
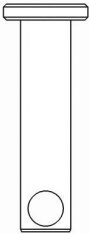
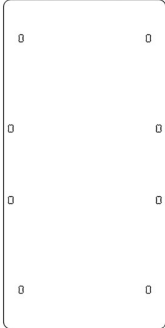
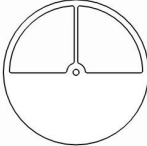

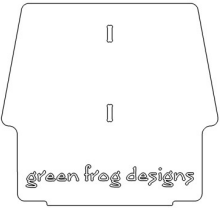
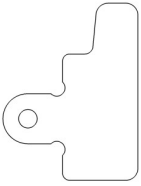
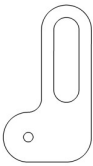
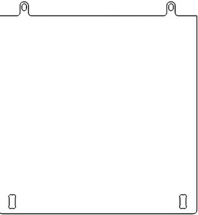
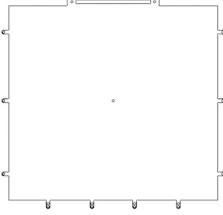

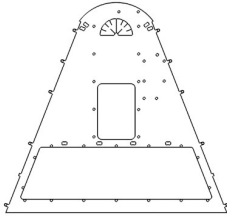
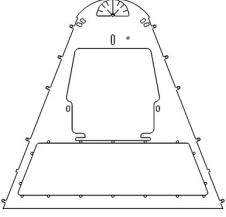
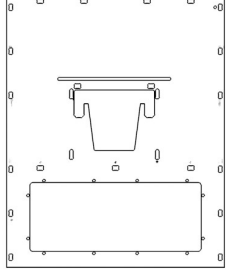
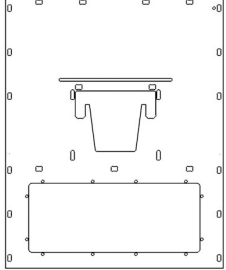
HOW TO FIT A LINC PIN (WHERE USED)

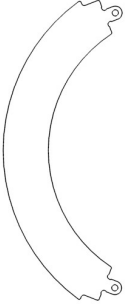
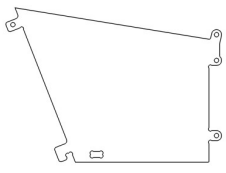
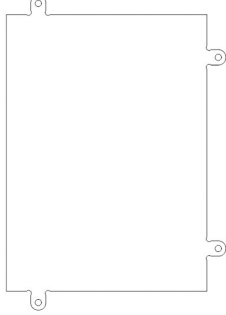

You only need to move the ring slightly away from the bar. They are designed to spring closed, so watch your fingers!

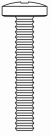
PARTS (Not to scale)

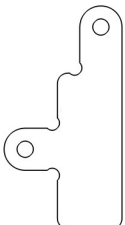
									
68x	Medium Clevis Pin	71x	6mm R-Clip	7x	30mm Screw	16x	40mm Screw	23x	Standard Washer
									
5x	25mm washer	23x	Nylock Nut	1x	Ramp	1x	Ramp Brace	2x	Perch
									
24x	Linch Pin	6x	Long Clevis Pin	1x	Roof	1x	Vent Cover	1x	Back Door Handle
									
1x	Back Door	2x	Back Door Retainer	1x	Back Door Lock	2x	Nest Box Roof	1x	Base

									
1x	Front Wall	1x	Back Wall	1x	Left Side Wall	1x	Right Side Wall	2x	Roof Brace
									
1x	Roof Arch	4x	Nest Box Sides (Mirrored pairs)	2x	Nest Box Base	2x	Nest Box Front	2x	Thin Door Retainer
									
2x	Thick Door Retainer	4x	M4 Nylock Nut	x4	25mm M4 Screw	4x	M4 Mini Washer	2x	Weather Seal (Short)
				<p>ALSO NEEDED:</p> <ul style="list-style-type: none"> 1 x VSB Control Unit 1 x VSB External Sensor 4 x VSB Pulley 1 x Hen House Gate 1 x Spare Cord 					
4x	Small Roof Bracket	2x	Large Roof Bracket	[Available Separately]					

DIMENSIONS

Dimensions: External 124(w) x 118(h) x 90(d) cm (excluding ramp and nestboxes)
Accommodation Size (max): 91(w) x 77(h) x 85(d) cm (excluding nest boxes)
Perch Length: 3 x 69 cm

TOOLS REQUIRED

Sharp knife (e.g. Stanley Knife) or Sand Paper
Large size cross head screwdriver
10mm ring spanner (or socket wrench or adjustable spanner)
Small flat-bladed screwdriver (optional)

PRE-ASSEMBLY CHECKS

Prior to assembly, check that you have all the required parts. Please be aware that, being a recycled material, some minor surface blemishes or defects may have occurred during manufacture. These will not affect the functionality of your product.

Trim any excess plastic using sand paper or a sharp knife. **(NOTE: Be careful to cut away from yourself.)**

If any parts are missing, please email sales@greenfrogdesigns.co.uk

Please state the part number, quantity missing, your phone number and your full postal address.

SPARE PARTS

Spare parts are available to order online via our website: www.greenfrogdesigns.co.uk

IMPORTANT NOTE

Due to the size and weight of the Chicken Loft, we recommend that it is built on site.

If it needs to be moved, carry weight can be reduced by temporary removal of the Nest Boxes and Roofs, and the Roof Panel.

HOW TO ASSEMBLE

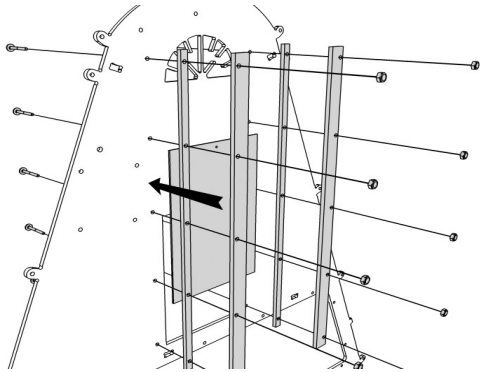
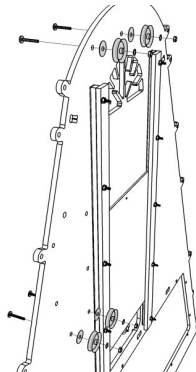
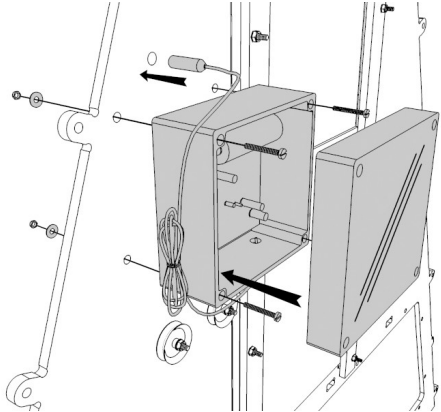
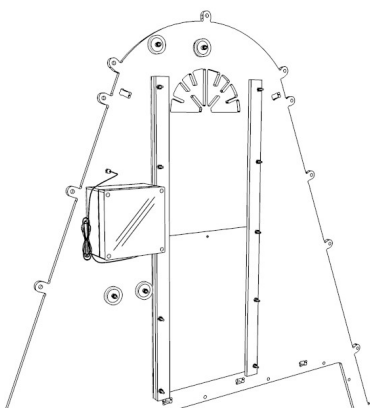
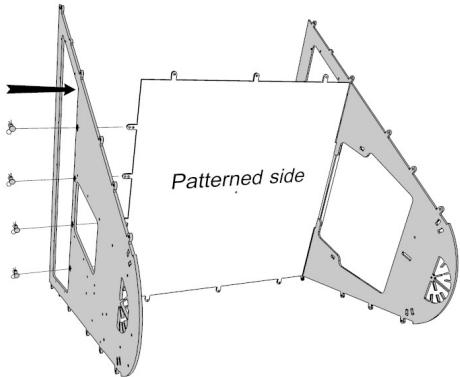
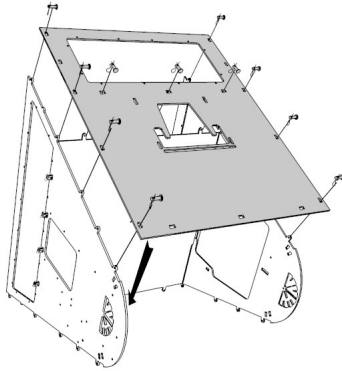
	
<p>1 Fit the Thin and Thick Door Retainers to the Non-Patterned side of the Front Wall, using 40mm Screws and secure using Nylock Nuts. Temporarily tape or tie the metal door into position so that it cannot fall out.</p>	<p>2 Fit the two Pulleys to the holes in the Non-Patterned side of the Front wall using 30mm Screws, 25mm Washers, Standard Washers and Nylock Nuts as shown. Do not tighten the nuts - the pulleys must rotate freely.</p>
	
<p>3 Attach the VSB box to the four holes in the non-patterned side of the Front Wall using the small M4 Screws, Washers and Nylock Nuts provided with it, then fit the VSB Cover (To protect it during the build). The Cable and Cord holes should be to the top. Fit the Light Sensor partway through the remaining hole (secure later with a dab of clear silicone sealant). Note: Do not insert the batteries at this time.</p>	<p>4 The VSB unit is now fitted. The Cord that attaches to the door is attached near the end of the build.</p>
	
<p>5 With the panels positioned as shown, attach the Back Wall and then the Front Wall to the Base using Medium Clevis Pins and R-Clips. Both walls should have the patterned side outermost.</p>	<p>6 Attach the Left Side Wall (pattern outermost) using Clevis Pins and R-Clips. Carefully turn the assembly over, and repeat for the Right Side Wall</p>

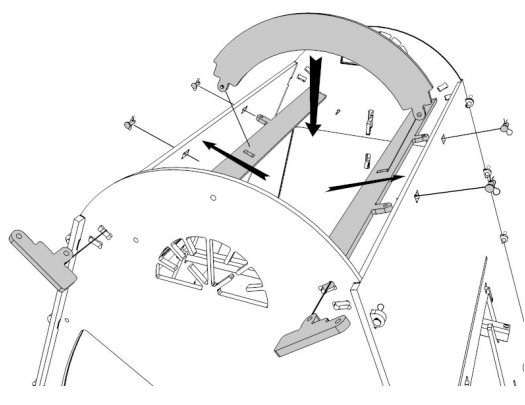
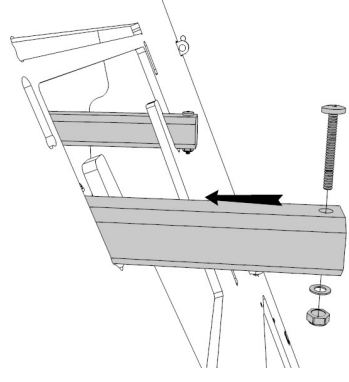
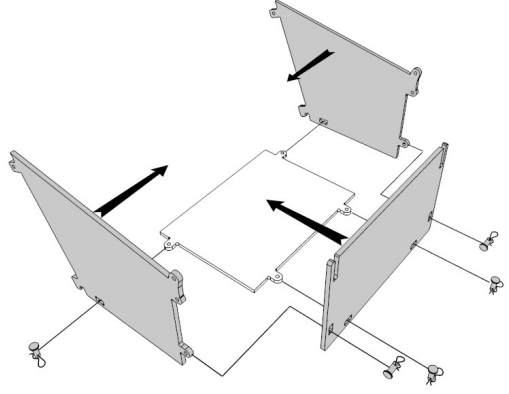
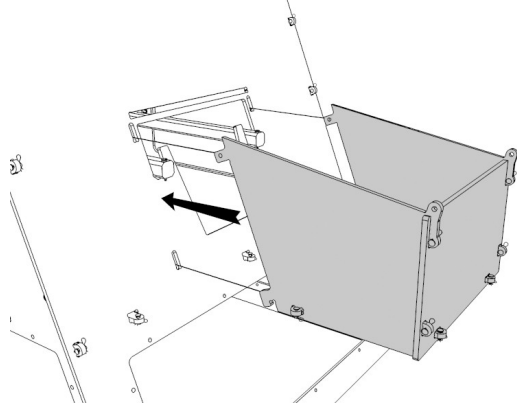
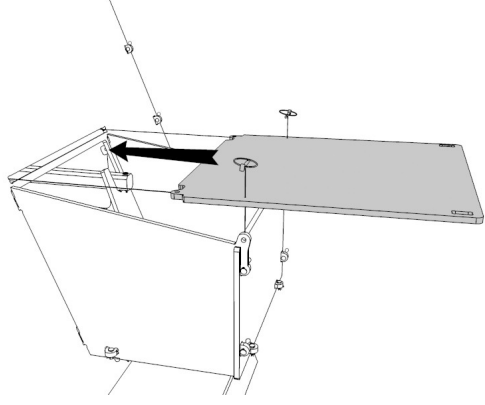
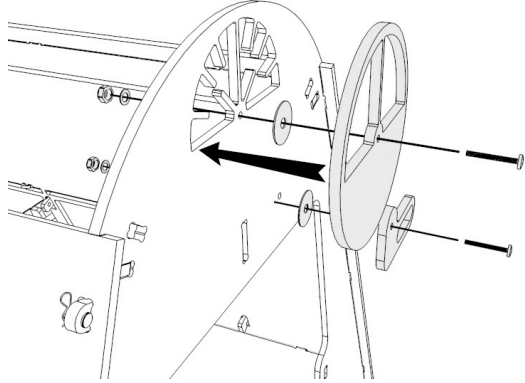
	
<p>7 Attach the Roof Braces and Small Roof Brackets using Clevis Pins and R-Clips. Use Long Clevis Pins for the two middle lugs on each brace. Start at one end and bend the bar to fit the other end tab – some force is required. Fit the Roof Arch using Clevis Pins and R-Clips.</p>	<p>8 Fit a 40mm Screw to each end of the 2 Perches and secure with a Standard Washer and Locknut. Place the perches in the perch rests.</p>
	
<p>9 Fit the Nest Box using Clevis Pins and R-Clips. Fit the Nest Box Sides to the Nest Box Base first, then the Nest Box Front (all with pattern outermost).</p>	<p>10 Fit the nest box to the house by first inserting the L-lugs into the lower holes on the Side Wall, then tilting the nest box to push the upper lugs through their holes, before securing them inside the main house with Linch Pins (not shown).</p>
	
<p>11 Fit the Nest Box Roof by pushing its lugs through the holes in the Side Wall and secure it with Linch Pins inside the main house. Two more Linch Pins are used outside – these can be quickly removed for daily access to the nest box. Repeat steps 7 to 9 for the other nest box.</p>	<p>12 Fit the Vent Cover to the Back Wall using an M6x30mm screw, a standard washer, a 25mm washer and a Nylock nut. Tighten the nut until the vent can rotate using gentle pressure. It should not spin freely. Fit the Door Lock using an M6x30mm screw, a standard washer, a 25mm washer and a Nylock nut.</p>

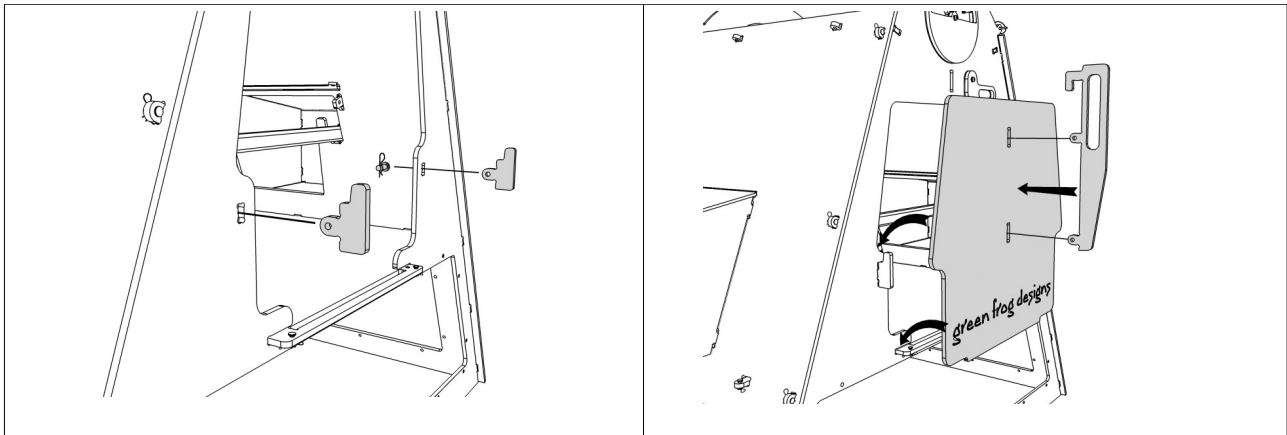

13 Fit the **Door Retainers** to the **Back Wall** using Clevis Pins and R-Clips.

14 Fit the **Back Door Handle** to the **Back Door** using **Medium Clevis Pins** and **R-Clips**. Fit the **Rear Door** by lowering the bottom of the door into the slots in the **Base** ensuring that the door slides down behind the **Door Retainers**. Slide the **Back Door Handle** downwards to hold the door in position. Secure it by rotating the **Door Lock**.

15

SETTING UP THE VSB ELECTRONIC DOORKEEPER

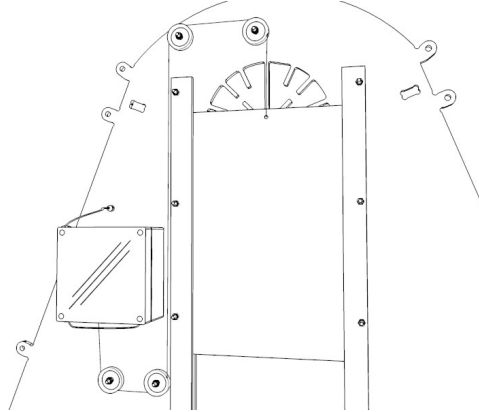

Before mounting the Electronic Doorkeeper, it is essential to read through the following instructions carefully, while reviewing the photos which follow (these are photos of a 'generic' VSB Doorkeeper installation).

Do **NOT** bend or "straighten" any of the internal parts of the VSB unit!

Do **NOT** apply any voltage to contacts 3 or 6 or damage will occur!

Do **NOT** carry out any functional tests before mounting the Doorkeeper.

Checking the VSB unit

Install four AA batteries. The blue lead from the battery holder should be connected to pin 1A (marked with a blue dot) and the red lead to Pin 2A (red dot). The cord should **not** be connected to the door at this stage.

Open the VSB control unit and cover the light sensor (marked **R2**) on the circuit board with the black plastic cap to simulate darkness. (**WARNING:** The light sensor is only attached to the circuit board by very fine wires. Place and remove the cap **very gently**, or you will break these wires and render the VSB unit inoperative). Draw out the cord a few inches by gently pulling the free end. It should stop when you release the pressure. This simulates the door lowering and then releasing the tension on the cord when it is in the fully down position. If it does not operate, check the battery connections and repeat.

Wait for a few minutes, and then uncover the light sensor. The cord should fully retract until the small bead by the loop in the cord enters the control unit, and then the motor should stop. This is the 'door fully up' (i.e. open) position.

If, following these checks, the unit does not operate properly, please call us for assistance.

Attaching the door

This should be done with the cord fully retracted into the VSB control unit (i.e. in its 'door fully up' position). Use a spare piece of string or sticky tape to temporarily hold the metal door in the fully open (i.e. up) position. Take the length of additional cord supplied and tie one end to the hole in the top of the door. Route the cord round the pulleys as shown in the diagram and, ensuring that there is about 1cm of slack, tie the other end to the loop of cord at the VSB unit. It is vital to have some slack, as the button on the cord **must** operate the micro-switch inside the control unit **before** the door comes into contact with the pulley.

Testing opening and closing

Remove the string holding the door open, and then cover the sensor with the cap to simulate darkness. The door should now lower completely and stop in the fully closed position (this is automatically detected by the VSB unit when the weight on the end of the cord becomes less than 200g).

Wait a few minutes and then uncover the sensor. After a few minutes, the cord should begin to rewind into the VSB unit and the door should rise until it is fully open.

Fitting the external light sensor

Refit the black plastic cap, ensuring that it fully covers the internal light sensor (this cap must remain in place during the normal working of the VSB unit when the external sensor is fitted). Connect the external light sensor to pins 5 and 6 in the VSB unit (either way round). **Note:** Ensure that the remote sensor wires do not foul any part of the VSB mechanism, cord or pulleys.

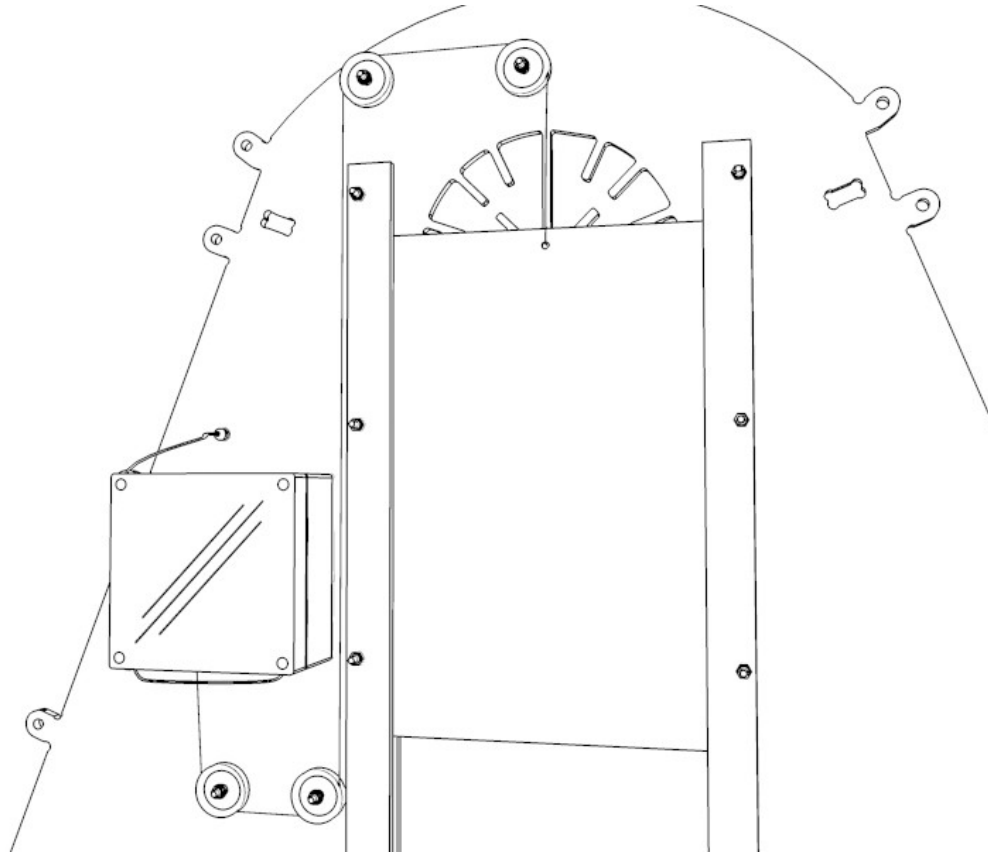

Cautionary Notes

Do not move, block or restrict any parts of the VSB unit. Be ready to disconnect the power if the unit does not shut off when the door reaches the fully open position.

If the door is blocked or the load exceeds 5 kg, the motor in the VSB should stop within seconds. When a blockage is removed, (or if the timer/sensor indicates otherwise) the motor will switch on again within 3 minutes. Strain on the battery is negligible.

Note: It is important that the external sensor be shielded from any artificial light sources, or it may open unexpectedly.

Varying the sensitivity

Sensitivity can be adjusted using the potentiometer above pins 5 and 6 (it has a white slot that takes a small flat-bladed screwdriver). This has been set in the factory so that the sliding gate door is closed relatively early. If it is still **too bright** when this happens, turn the potentiometer **clockwise** and check the operation again. Continue to adjust as necessary. (**WARNING:** Be gentle when turning the potentiometer – excess force will cause damage).

Pull cord servicing

Check the condition of the pull cord at regular intervals. The pull cord should have a service life of about 10 years, but eventually the cord may break. To replace the cord, cover the light sensor to simulate darkness and draw out the complete cord by gently pulling the free end. Do **not** pull the cord with significant force. Replace the old cord with a new one (nylon fishing line is ideal) carefully following the routing of the cord within the VSB unit, ensuring that the knot is in the same place as before. Then uncover the sensor and allow the cord to be rewound into the VSB unit.

Maintenance

No routine servicing is required. Batteries should be replaced every 12 months. You can apply a very small amount of spray grease to the bearing bolts of the plastic gears if they should generate severe noise. Do **not** lubricate the pull cord.

Battery-powered timer BS (Optional extra)

A battery-powered timer (BS) can be used to open and close the sliding gate door according to a time setting or to open it according to a time setting and close it in response to light conditions at dusk. Fitting details are available on request.

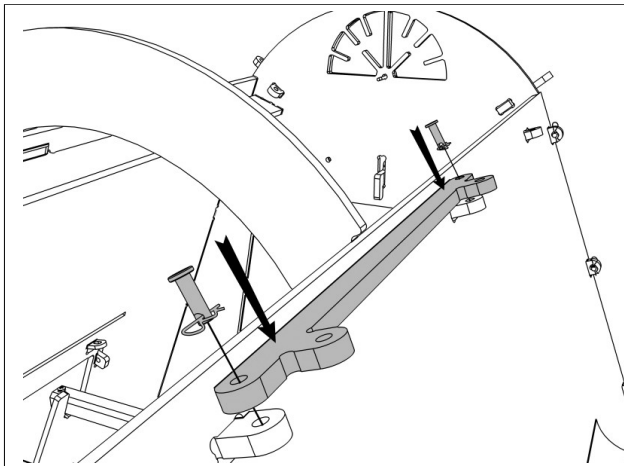

- 16** Attach the two **Large Roof Brackets** above the centre two lugs on the **Roof Braces** using the **Long Clevis Pins** and **R-Clips** already in place.

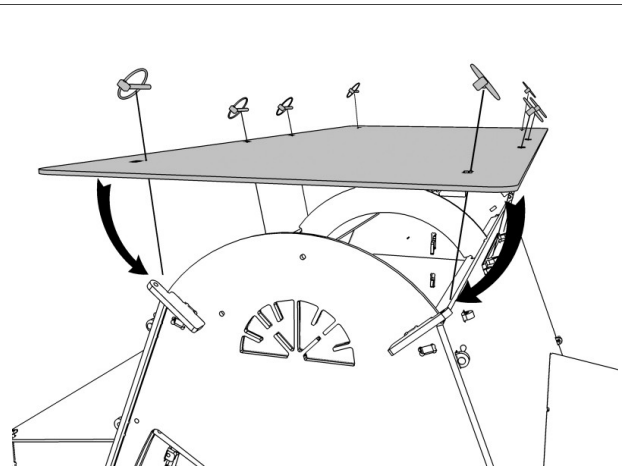

- 17** Fit the **Roof** using **Lynch Pins**. Fix the centre first, then bend the sides down over the remaining lugs.
Do the ends first, followed by the middle. Some force may be required when the roof is fitted for the first time.

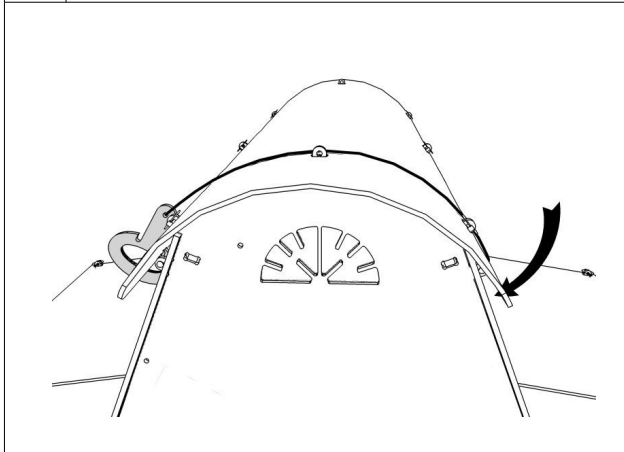

- 18** Pass the end of the **Door Cord** through the hole in the top of the **Right Side Wall** before tying it to the small hole in the **Door Handle**. The **Cord** length should be adjusted so that, when the door is fully raised, the slot in the handle just hooks onto the far edge of the roof.

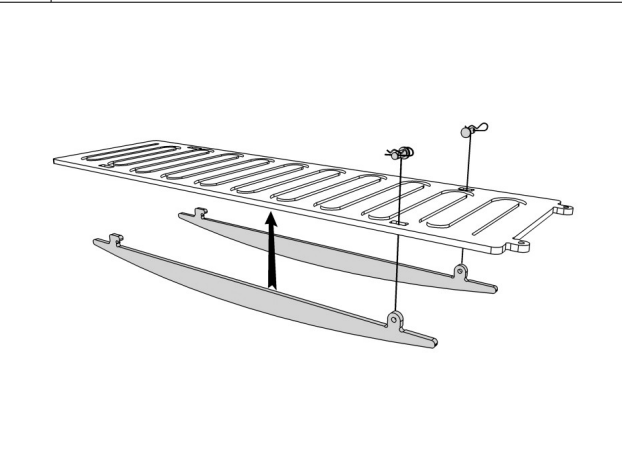

- 19** Attach the **Ramp Braces** to the **Ramp** using two **Medium Clevis Pins** and **R-Clips**.

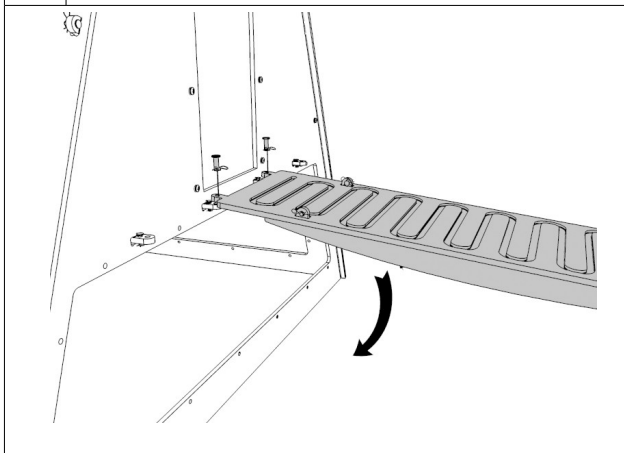

- 20** Fit the **Ramp** in front of the doorway using two **Long Clevis Pins** and **R-Clips**. Lift it to fit, and then allow it to tilt to the ground under its own weight.

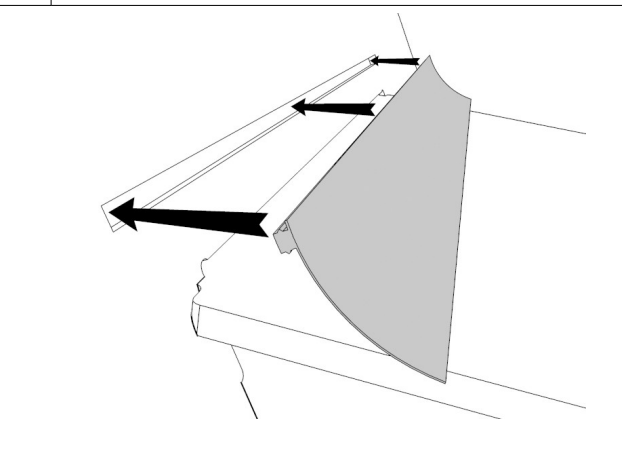

- 21** Push the **Weather Seals** fully home into the slots above the **Nest Boxes** (Note: you may need to trim them to the correct length first). Start at one end and work your way along, pushing firmly. It may help to lubricate with a little washing-up liquid.

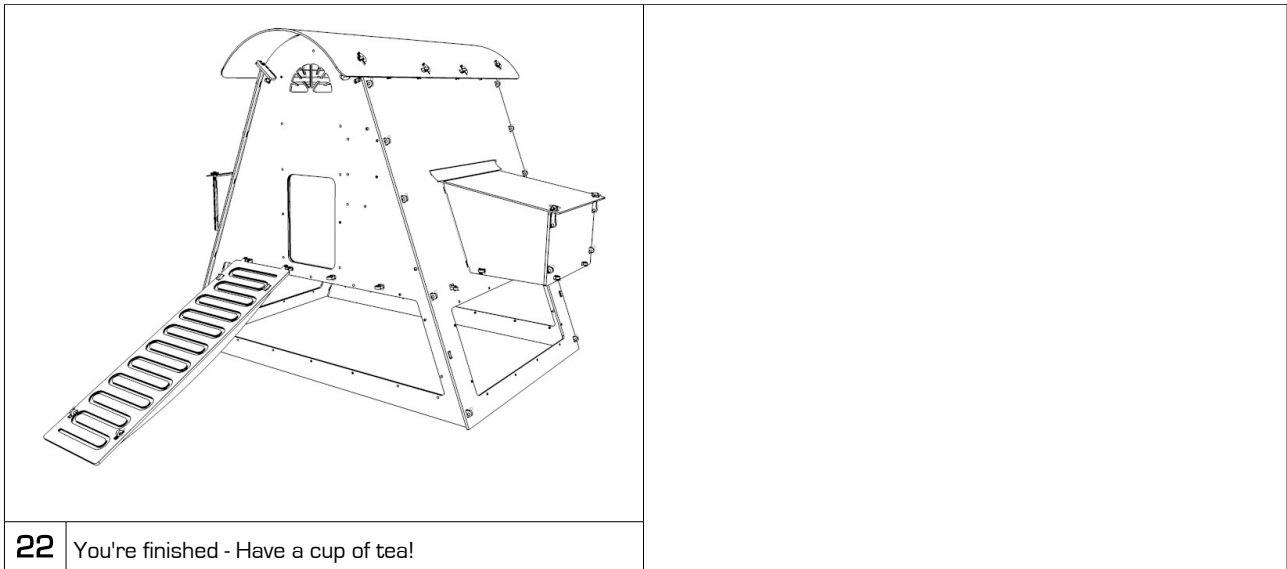

INSTRUCTIONS FOR USE

The Loft should be sited in a sheltered area with the front facing away from prevailing winds. The Vent should be adjusted to provide adequate ventilation.

Your chickens are likely to shelter under the house. Added protection can be provided by fitting metal mesh panels into the cutouts low on the sides and ends using cable ties (mesh and ties are not included).

The rear door provides access for inspection, for replacing of shavings/straw and regular cleaning. For thorough cleaning, the entire roof and nest boxes can be removed. We recommend thorough cleaning at least every 3 months – a pressure washer is ideal for removal of caked on dirt, but an ordinary hosepipe and scrubbing brush will do. The plastic is quite easy to clean. Finish by applying Poultry Shield (or similar) and leave to dry.