

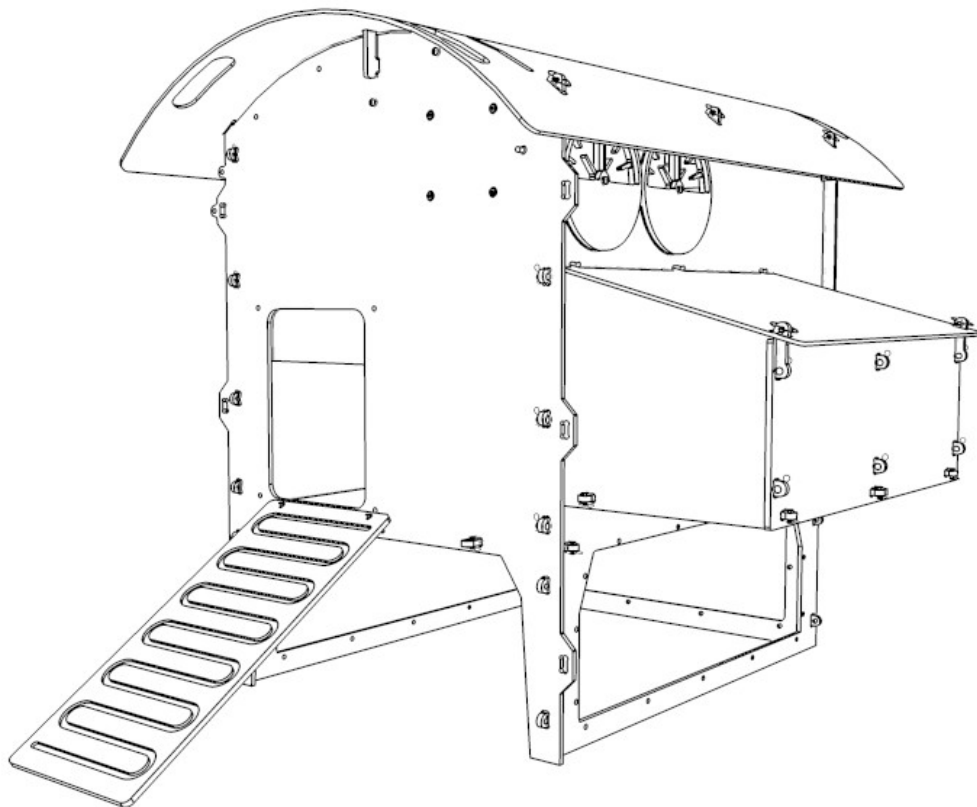

HOW TO ASSEMBLE, USE AND CARE FOR YOUR Chicken Lodge (Medium) VSB



RECYCLED & RECYCLABLE

Products from green frog designs are made, wherever possible, from materials that are recycled. Where this is not practical, we always try to use materials that are suitable for recycling.

Our plastic is made from recycled waste plastic, predominantly plastic wrapping and carrier bags. By choosing our products, rather than those made from virgin plastic, you are helping to restrict the amount of new plastic being made. We recycle all our waste plastic and, of course, our products themselves can be recycled (if they ever wear out!!).

The recycled plastic we use is incredibly tough, but is as easily worked as wood. There is no need for preservative treatment with insecticides or fungicides, and structures won't splinter or crack, so they retain their structural integrity well. The plastic is resistant to UV light, so it retains its colour well, and is pretty much impervious to atmospheric pollutants and seasonal climatic actions such as freeze-thaw. It insulates quite well, and is also resistant to chewing. These properties mean that it retains its appearance, colour and functionality for much longer than timber.

The sheets of recycled plastic have a very uniform thickness, and so are ideally suited to our high-technology manufacturing process, which uses computer-controlled machines to cut shapes to accuracies better than 0.1mm.

We also use some metal components to fix parts together. The metals used are either stainless steel or other rust-resistant alloy, so they have a very long lifetime. They are also suitable for recycling.

Our packaging and literature is all made from recycled materials wherever possible. For example, assembly instructions are printed on recycled paper, and we use recycled plastic bubble-wrap in our packaging. Even our business cards are made from 80% recycled card.

In other words: **Fun, functional products that don't cost the Earth!**



HOW TO FIT A CLEVIS PIN (IF USED)

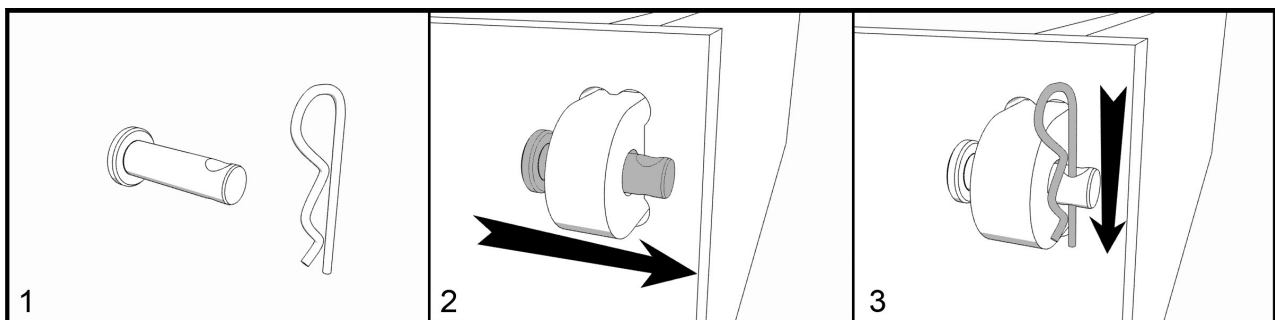



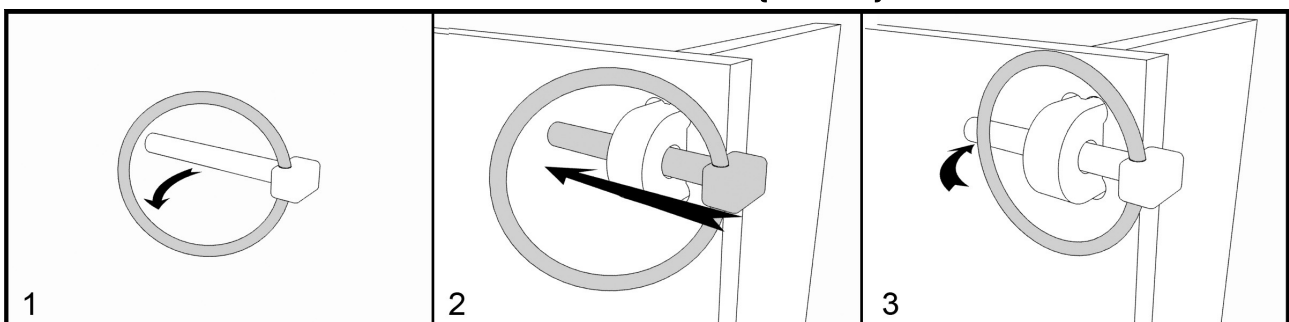





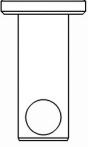

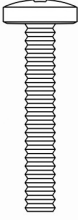
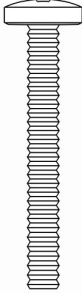

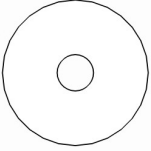

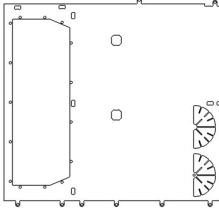
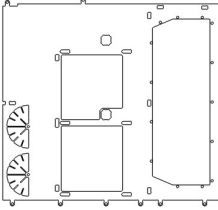
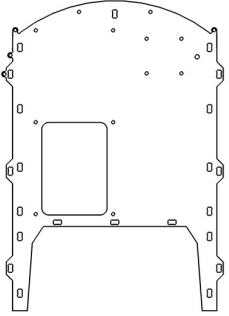
HOW TO FIT A LINCH PIN (IF USED)

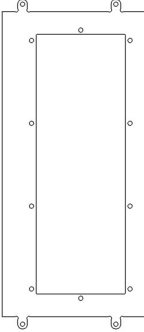
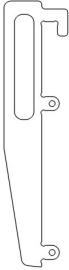
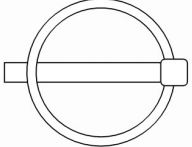
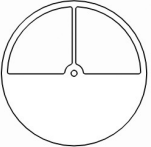
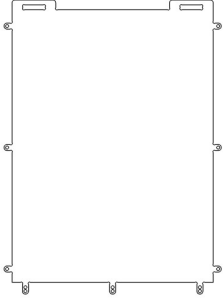
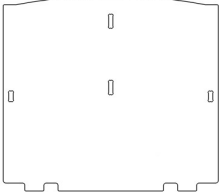

You only need to move the ring slightly away from the bar. They are designed to spring closed, so watch your fingers!

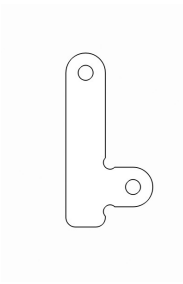
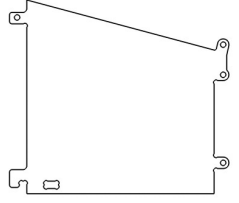
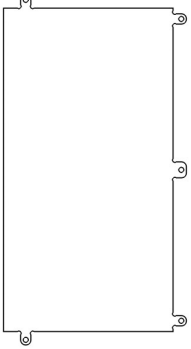
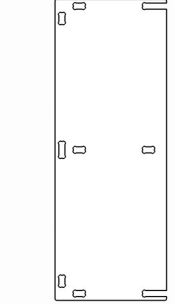
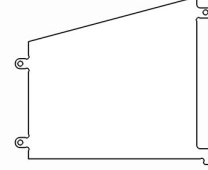
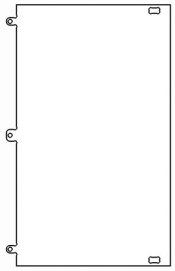
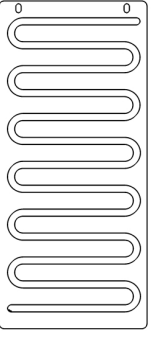
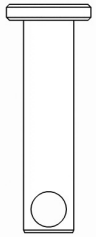
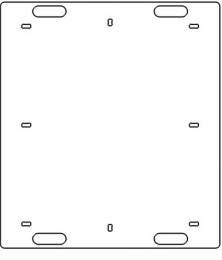
PARTS (Not to scale)

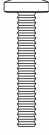
				
42x Medium Clevis Pin	45x 6mm R-Clip	5x 30mm Screw	6x 40mm Screw	11x Standard Washer
				
4x 25mm washer	11x Nylock Nut	1x Left Side Wall (No square holes on non-perch model)	1x Right Side Wall (No square hole on non-perch model)	1x Front Wall
				
2x Thin Door Retainer	2x Thick Door Retainer	1x Lower Back Wall	1x Back Door Handle	23x Linch Pin (19 on Non-Perch model)
				
3x Vent Cover	1x Base	1x Back Door	1x Upper Back Wall	1x Roof Support

									
2x	Roof Clip	2x	Nest Box End Wall	1x	Nest Box Floor	1x	Nest Box Front Wall	1x	Nest Box Divider
									
1x	Nest Box Roof	1x	Ramp	2x	Long Clevis Pin	1x	Roof	2x	Perch (Perch models only)
			OTHER ITEMS 1 x VSB Control Unit 1 x VSB External Sensor 2 x VSB Pulley 1 x Hen House Gate						
4x	M4 Nylock Nut	4x	25mm M4 Screw	4x	M4 Mini Washer	(Available Separately)			

DIMENSIONS

External Dimensions:

94 (w) x 99 (h) x 81 (d) cm (excluding ramp & roof overhang, but including nest boxes)

Internal Floorspace:

59 (w) x 79 (d) cm (excluding nest boxes)

TOOLS REQUIRED

Sharp knife (e.g. Stanley Knife) or Sand Paper

Large size cross head screwdriver

10mm ring spanner (or socket wrench or adjustable spanner)

Small flat-bladed screwdriver (optional)

PRE-ASSEMBLY CHECKS

Prior to assembly, check that you have all the required parts. Please be aware that, being a recycled material, some minor surface blemishes or defects may have occurred during manufacture. These will not affect the functionality of your product.

Trim any excess plastic using sand paper or a sharp knife. **(NOTE: Be careful to cut away from yourself.)**

If any parts are missing, please email sales@greenfrogdesigns.co.uk

Please state the part number, quantity missing, your phone number and your full postal address.

SPARE PARTS

Spare parts are available to order online via our website: www.greenfrogdesigns.co.uk

HOW TO ASSEMBLE

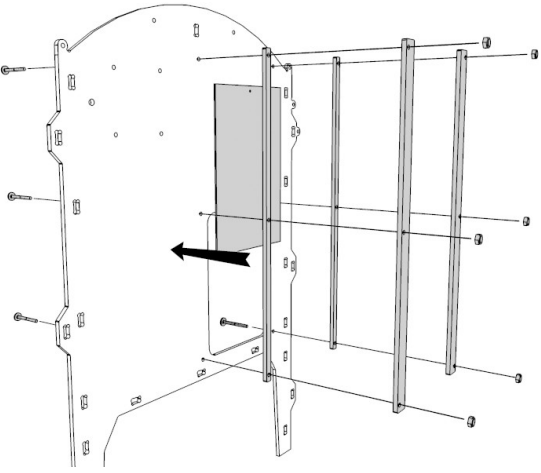
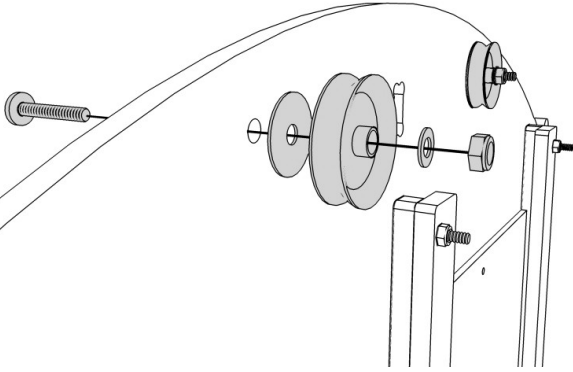
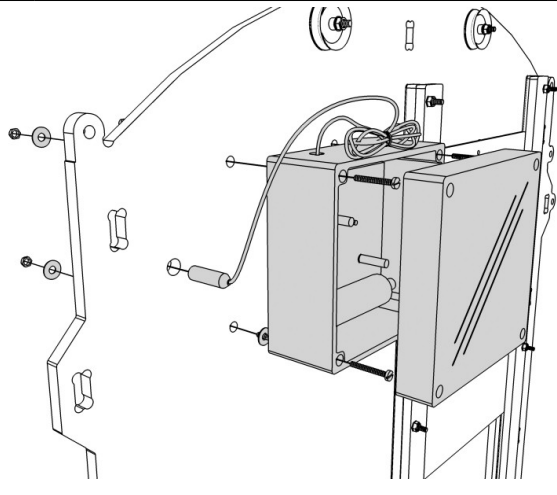
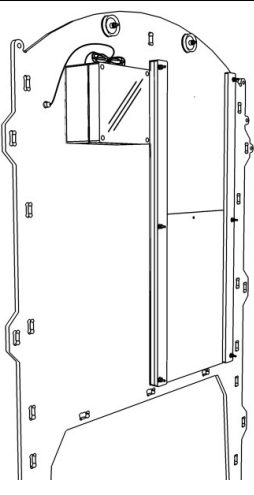
	
<p>1 Fit the Thin Door Retainers and then the Thick Door Retainers into the holes in the Non-Patterned side of the Front Wall, using 40mm Screws and secure using a Nylock Nuts.</p>	<p>2 Fit the two Pulleys to the holes in in the Non-Patterned side of the Front wall using 30mm Screws, 25mm Washers, Standard Washers and Nylock Nuts as shown. Do not tighten the nuts – the pulleys must rotate freely.</p>
	
<p>3 Attach the VSB box to the four holes in the non-patterned side of the Front Wall using the small M4 Screws, Washers and Nylock Nuts provided with it, then fit the VSB Cover (To protect it during the build). The Cable and Cord holes should be to the top. Fit the Light Sensor partway through the remaining hole [secure later with a dab of clear silicone sealant]. Note: Do not insert the batteries at this time.</p>	<p>4 The VSB unit is now fitted. The Cord that raises the door is attached near the end of the build – for now, just leave it free.</p>

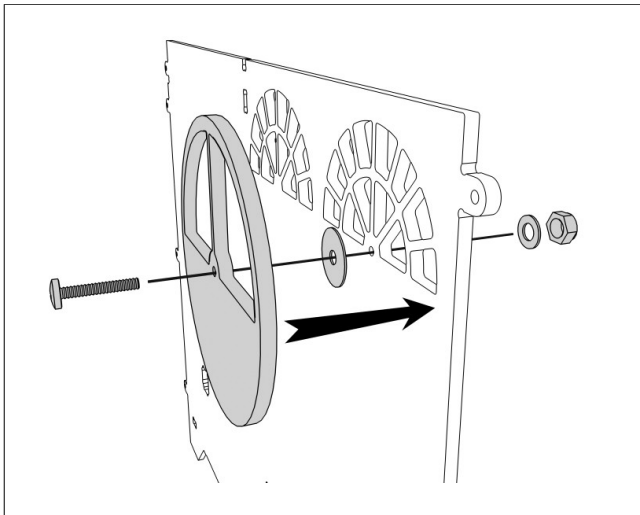

5 Fit one **Vent Cover** to the gridded side of the **Left Side Wall** using an **M6x30mm screw**, a **standard washer**, a **25mm washer** and a **nylock nut** (as shown in the diagram above). Tighten the nut until the vent can rotate using gentle pressure. It should not spin freely.
Fit the other two **vent covers** to the **Right Side Wall** in the same way.
The fourth vent does not have a cover, to ensure the chickens have some fresh air at all times.

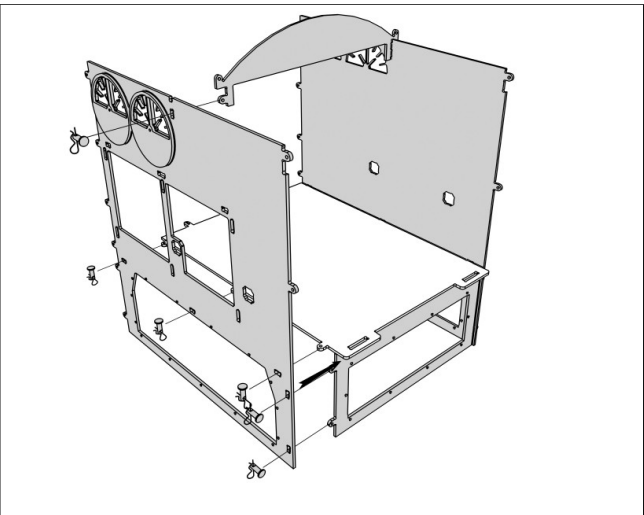

6 Fit both **Side Walls** to the **Base** using **Medium Clevis Pins** and **Retaining Clips (R-Clips)** Ensure that the **Double-hole lugs** are at the front.
Fit the **Roof Support** and the **Lower Back Wall** between the two side walls.
NOTE: The **Base** may be fitted either way up (smooth side or patterned side) as required. The smooth side is easier to clean, whilst the patterned side provides more grip, which may be important if you are housing chicks.

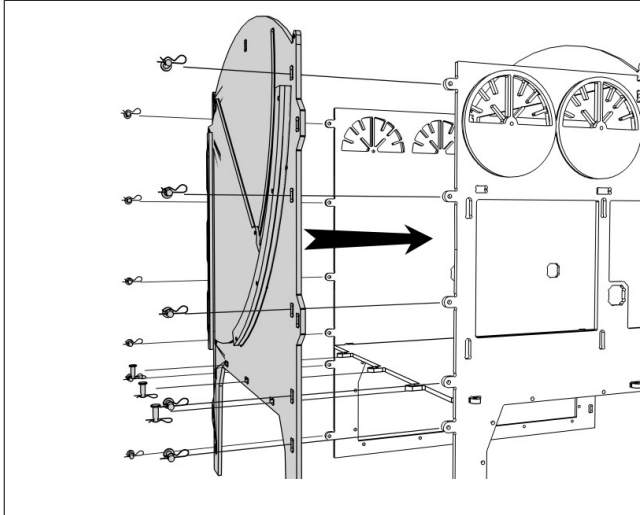

7 Fit the **Front Wall** (patterned face outermost) to the end with the **double-hole lugs** using **Medium Clevis Pins** and **R-Clips**.

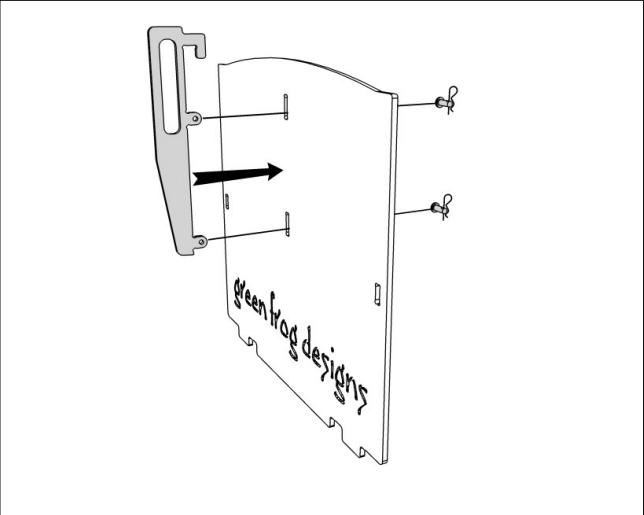

8 Fit the **Back Door Handle** to the **Back Door** using **Medium Clevis Pins** and **R-Clips**.

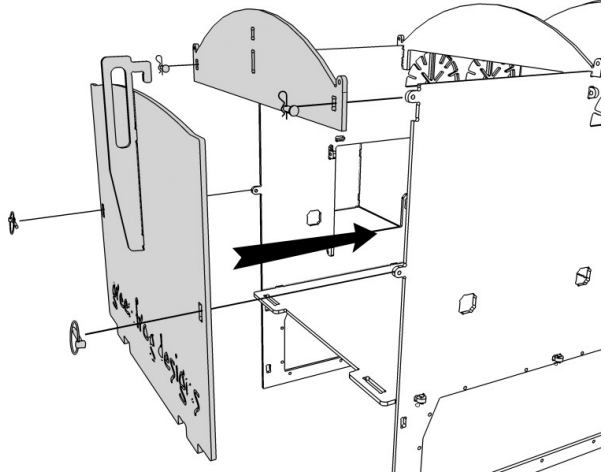
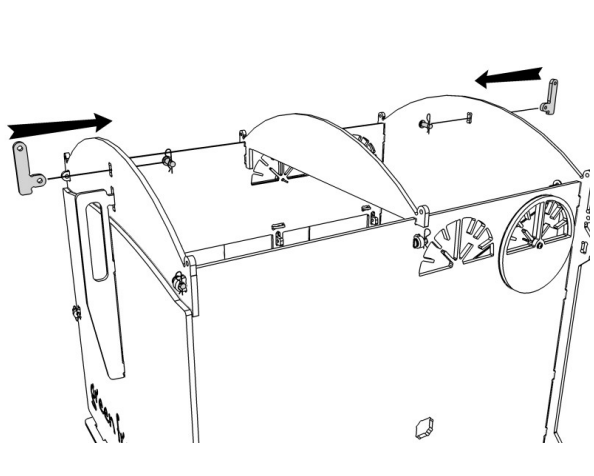
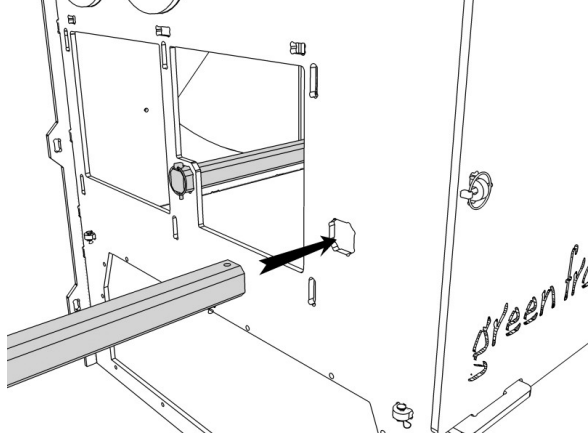
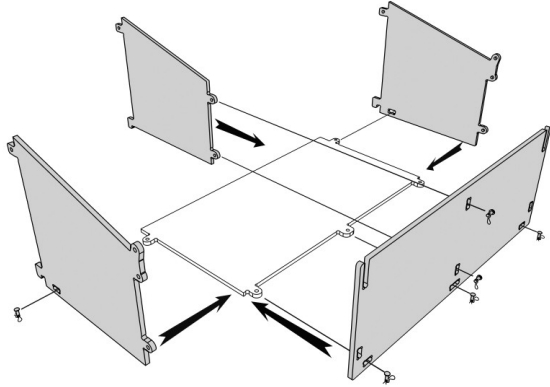
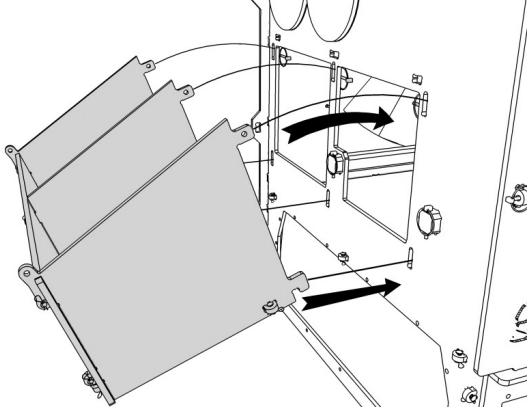
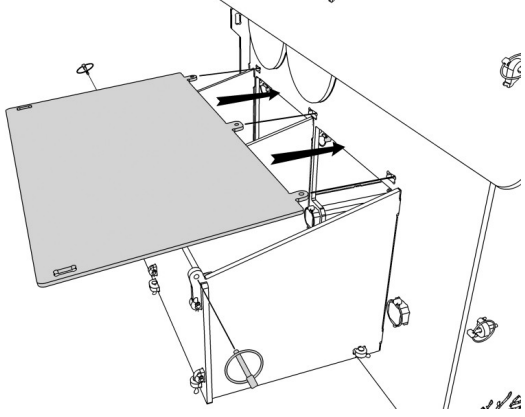
	
<p>9 Fit the Upper Back Wall using Medium Clevis Pins and then the Back Door using Linch Pins. (When fitting, rest the bottom of the Back Door in the slots in the Base first, push the door onto the lugs, and slide the Back Door Handle downwards to lock the Back Door.)</p>	<p>10 Fit Roof Clips to the Front Wall and Upper Back Wall using Medium Clevis Pins and R-Clips.</p>
	
<p>11 [Note: Skip this step for non-perch models] Slide the Perches through the Left and Right Side Walls and secure with Linch Pins at both ends.</p>	<p>12 Fit the Nest box End Walls to the Nest Box Floor using Medium Clevis Pins and R-Clips.</p>
	
<p>13 Fit the nest box to the house by first inserting the L-lugs into the lower holes on the Right Side Wall, then tilting the nest box to push the three upper lugs through their holes, before securing them inside the main house with Linch Pins.</p>	<p>14 Fit the Nest Box Roof by pushing its lugs through the holes in the Right Side Wall and secure it with Linch Pins inside the main house. Two more Linch Pins are used outside – these can be quickly removed for daily access.</p>

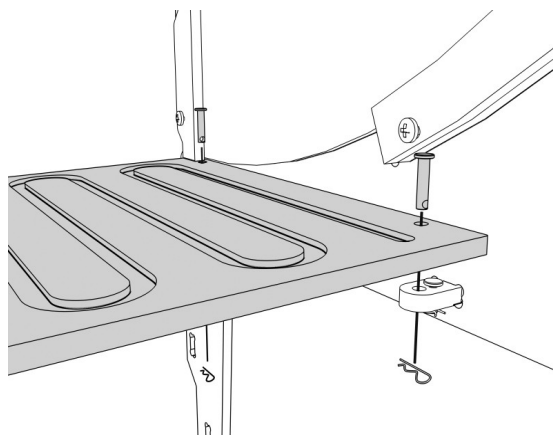

15 Fit the Ramp under the door using the two Long Clevis Pins and R-Clips. It will tilt to the ground under its own weight.

16 **SETTING UP THE VSB ELECTRONIC DOORKEEPER**

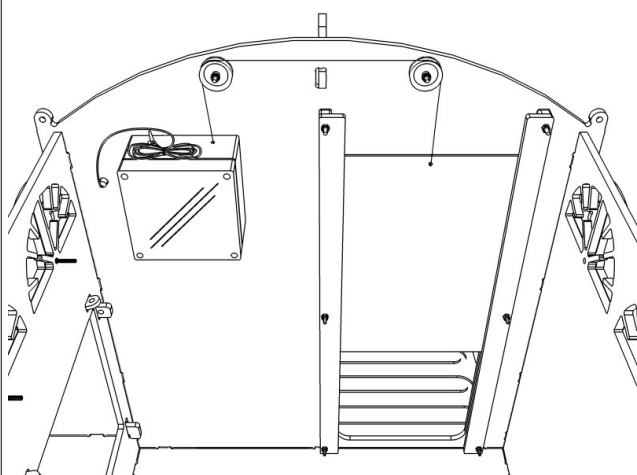

Before mounting the Electronic Doorkeeper, it is essential to read through the following instructions carefully, while reviewing the photos which follow (these are photos of a 'generic' VSB Doorkeeper installation).

Do **NOT** bend or "straighten" any of the internal parts of the VSB unit! Be **especially gentle** with the light sensor on the printed circuit board – if you try to straighten it you may break it off!

Do **NOT** apply any voltage to contacts 3 or 6 or damage will occur!

Do **NOT** carry out any functional tests before mounting the Doorkeeper.

Checking the VSB unit

Install four AA batteries. The blue lead from the battery holder should be connected to pin 1A (marked with a blue dot) and the red lead to Pin 2A (red dot). The cord should **not** be connected to the door at this stage, and the door should be in the fully down (i.e. closed) position.

Open the VSB control unit and cover the light sensor (marked **R2**) on the circuit board with the black plastic cap to simulate darkness. Draw out the cord a few inches by gently pulling the free end. It should stop when you release the pressure. If it does not operate, check the battery connections and repeat. If it still does not operate, call us for assistance.

Wait for a few minutes, and then uncover the light sensor. The cord should fully retract to the fully down (i.e. closed) position.

Attaching the door

With the cord fully retracted into the VSB unit, the system is in its 'door fully open' position. Use a spare piece of string or sticky tape to temporarily fix the door in the fully up (i.e. open) position. Take the length of additional cord supplied and tie one end to the hole in the top of the door. Route the cord round the pulleys as shown in the diagram and, ensuring that there is minimal slack, tie the other end to the loop of cord at the VSB unit.

Testing opening and closing

Cover the sensor with the cap again to simulate darkness – the door should lower completely and stop in the fully closed position (this is automatically detected by the VSB unit when the weight on the end of the cord becomes less than 200g).

Now uncover the sensor. After a few minutes, the cord should begin to rewind into the VSB unit and the door should rise until it is fully open.

Fitting the external light sensor

Refit the black plastic cap, ensuring that it fully covers the internal light sensor. This cap remains in place during the normal working of the VSB unit. Now connect the outside light sensor to pins 5 and 6 in the VSB unit (either way round). **Note:** Ensure that the remote sensor wires do not foul any part of the VSB mechanism, cord or pulleys.

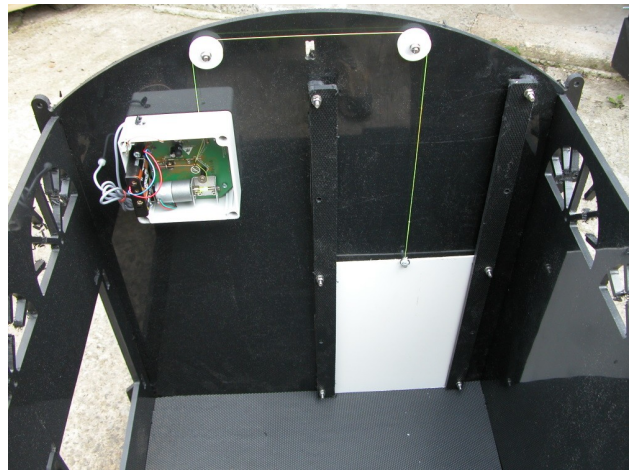
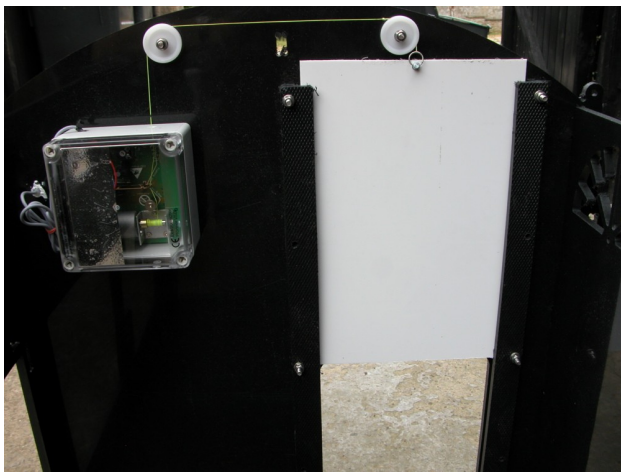

Cautionary Notes

Do not move, block or restrict any parts of the VSB unit. Be ready to disconnect the power if the unit does not shut off when the door reaches the fully open position.

If the door is blocked or the load exceeds 5 kg, the motor in the VSB should stop within seconds. When a blockage is removed, (or if the timer/sensor indicates otherwise) the motor will switch on again within 3 minutes. Strain on the battery is negligible.

Note: It is important that the external sensor be shielded from any artificial light sources, or it may open unexpectedly.

Varying the sensitivity

Sensitivity can be adjusting using the potentiometer above pins 5 and 6 (it has a white slot that takes a small flat-bladed screwdriver). This has been set in the factory so that the sliding gate door is closed relatively early. If it is still **too bright** when this happens, turn the potentiometer **clockwise** and check the operation again. Continue to adjust as necessary.

Pull cord servicing

Check the condition of the pull cord at regular intervals. The pull cord should have a service life of about 10 years, but eventually the cord may break. To replace the cord, cover the light sensor to simulate darkness and draw out the complete cord by gently pulling the free end. Do **not** pull the cord with significant force. Replace the old cord with a new one (nylon fishing line is ideal) carefully following the routing of the cord within the VSB unit, ensuring that the knot is in the same place as before. Then uncover the sensor and allow the cord to be rewound into the VSB unit.

Maintenance

No routine servicing is required. Batteries should be replaced every 12 months. You can apply a very small amount of spray grease to the bearing bolts of the plastic gears if they should generate severe noise. Do **not** lubricate the pull cord.

Battery-powered timer BS (Optional extra)

A battery-powered timer (BS) can be used to open and close the sliding gate door according to a time setting or to open it according to a time setting and close it in response to light conditions at dusk. Fitting details are available on request.

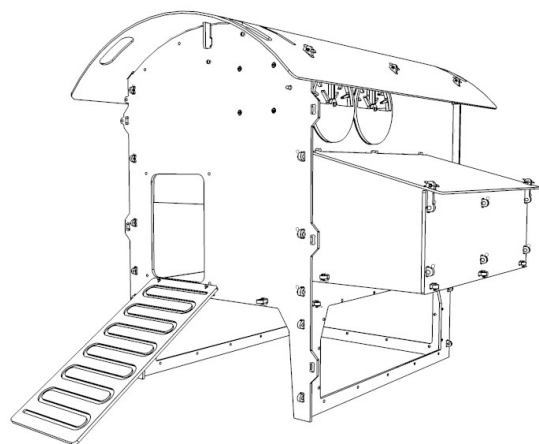
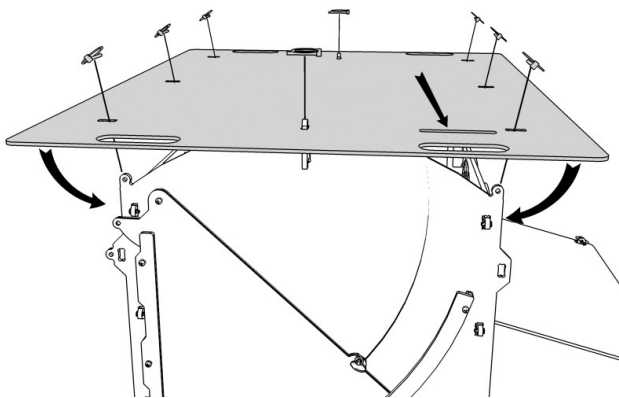

17 Fit the **Roof** using **Linch Pins**. Fix the centre first, then bend the sides down over the remaining lugs. Ensure the Handle hole is to the front.

18 You're finished - Have a cup of tea!

INSTRUCTIONS FOR USE

The Chicken Lodge should be sited in a sheltered area with the front facing away from prevailing winds. Vents should be adjusted to provide adequate ventilation. At least one hole should always be open.

The rear door can be used for inspection, and regular cleaning. For thorough cleaning and replacing of bedding, the entire roof can be removed.

This Chicken Lodge is designed to be moved by two people, using the handholds cut into the roof.

We recommend thorough cleaning at least every 3 months – a pressure washer is ideal for removal of caked on dirt, but an ordinary hosepipe and scrubbing brush will do. The plastic is quite easy to clean. Finish by applying Poultry Shield (or similar) and leave to dry.