

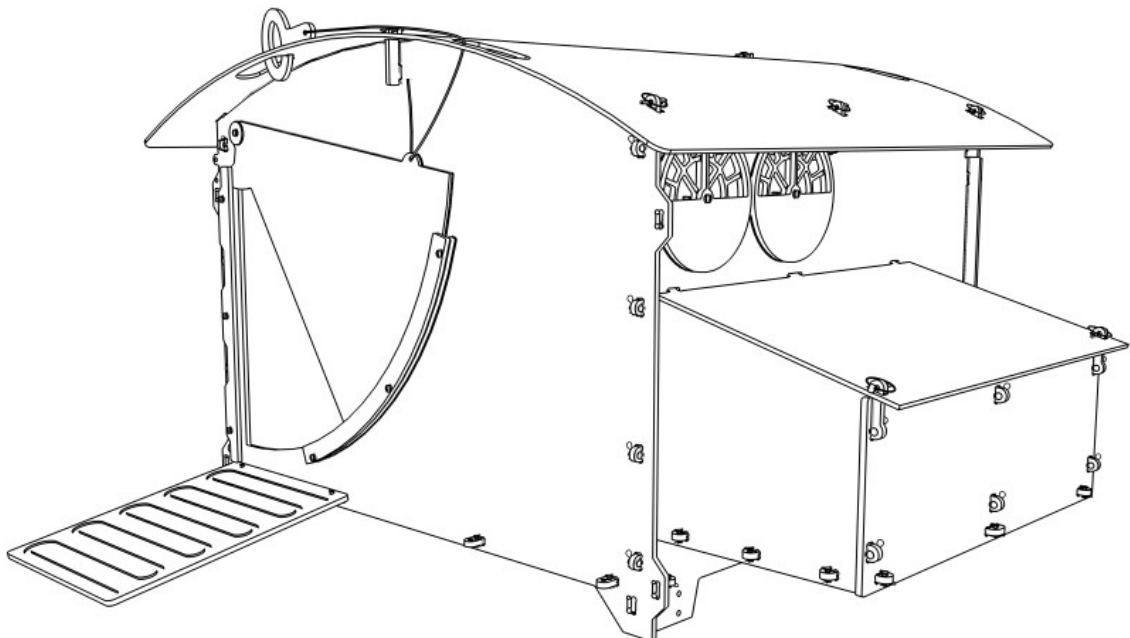

HOW TO ASSEMBLE, USE AND CARE FOR YOUR Chicken House (Large)



RECYCLED & RECYCLABLE

Products from green frog designs are made, wherever possible, from materials that are recycled. Where this is not practical, we always try to use materials that are suitable for recycling.

Our plastic is made from recycled waste plastic, predominantly plastic wrapping and carrier bags. By choosing our products, rather than those made from virgin plastic, you are helping to restrict the amount of new plastic being made. We recycle all our waste plastic and, of course, our products themselves can be recycled (if they ever wear out!!).

The recycled plastic we use is incredibly tough, but is as easily worked as wood. There is no need for preservative treatment with insecticides or fungicides, and structures won't splinter or crack, so they retain their structural integrity well. The plastic is resistant to UV light, so it retains its colour well, and is pretty much impervious to atmospheric pollutants and seasonal climatic actions such as freeze-thaw. It insulates quite well, and is also resistant to chewing. These properties mean that it retains its appearance, colour and functionality for much longer than timber.

The sheets of recycled plastic have a very uniform thickness, and so are ideally suited to our high-technology manufacturing process, which uses computer-controlled machines to cut shapes to accuracies better than 0.1mm.

We also use some metal components to fix parts together. The metals used are either stainless steel or other rust-resistant alloy, so they have a very long lifetime. They are also suitable for recycling.

Our packaging and literature is all made from recycled materials wherever possible. For example, assembly instructions are printed on recycled paper, and we use recycled plastic bubble-wrap in our packaging. Even our business cards are made from 80% recycled card.

In other words: **Fun, functional products that don't cost the Earth!**



HOW TO FIT A CLEVIS PIN (IF USED)

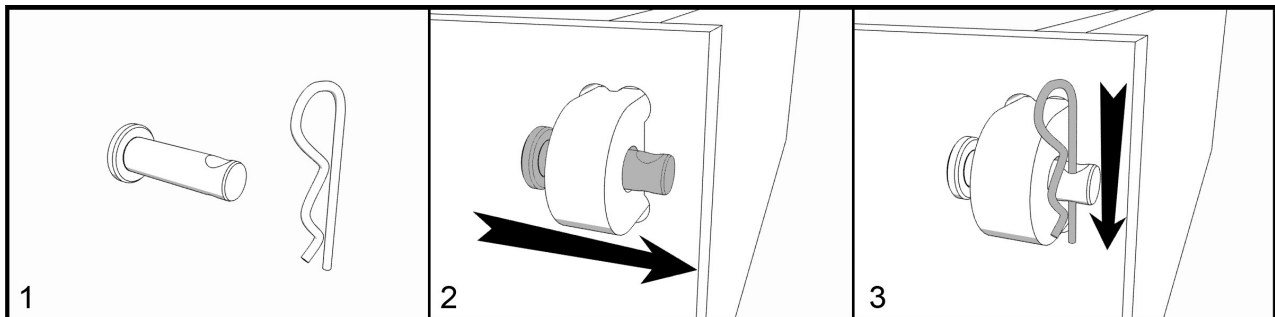



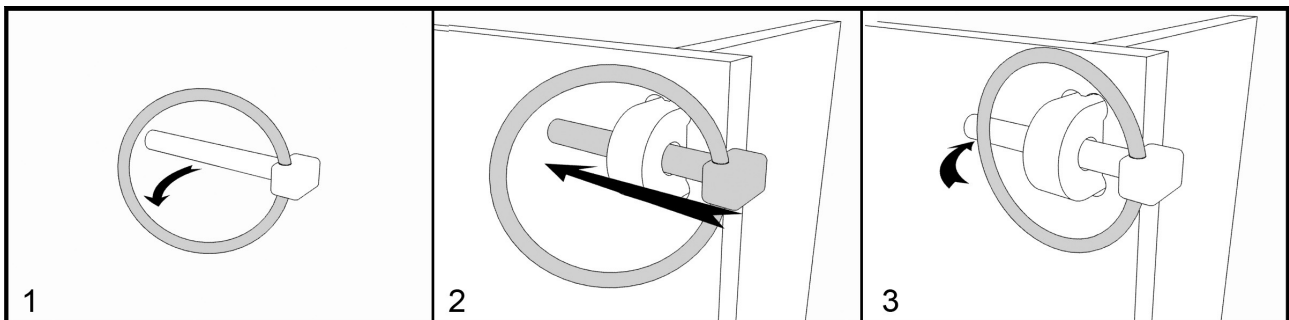





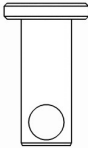

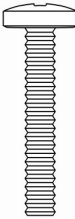
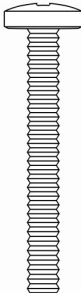

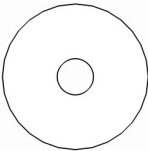

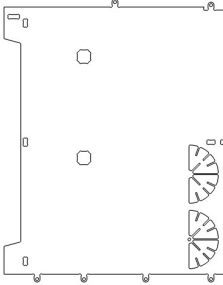
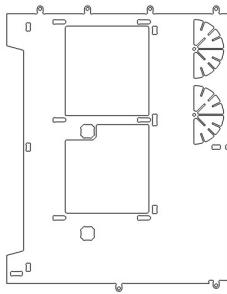
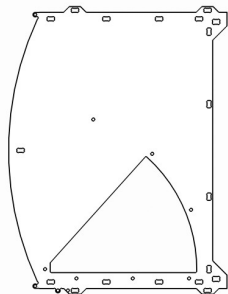

HOW TO FIT A LINCH PIN (IF USED)

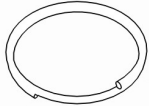
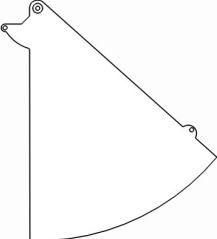
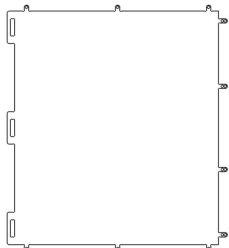
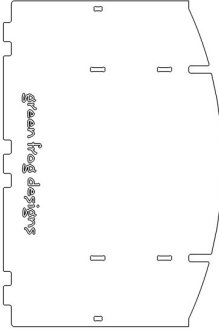

You only need to move the ring slightly away from the bar. They are designed to spring closed, so watch your fingers!

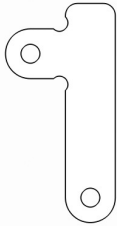
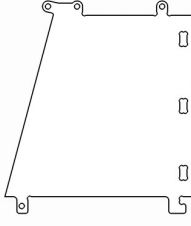
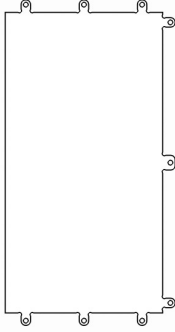
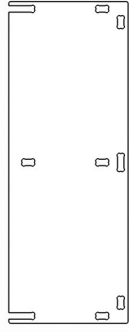
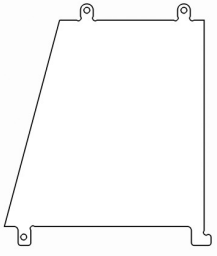
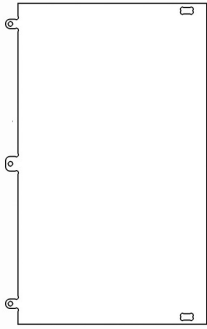
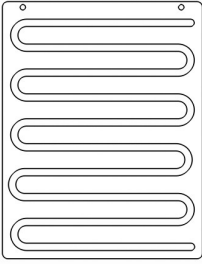
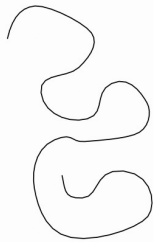
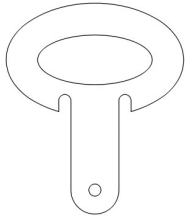
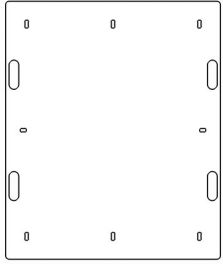
PARTS (Not to scale)

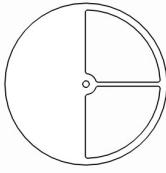
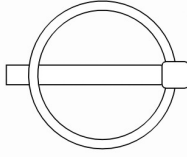
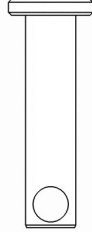
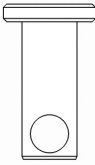
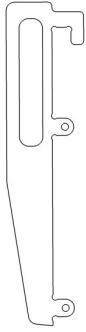
				
44x Medium Clevis Pin	47x 6mm R-Clip	4x 30mm Screw	6x 40mm Screw	10x Standard Washer
				
4x 25mm washer	10x Nylock Nut	1x Left Side Wall (No square holes on non-perch model)	1x Right Side Wall (No square hole on non-perch model)	1x Front Wall
				
1x Small Curved Door Retainer	1x Large Curved Door Retainer	1x Small Straight Door Retainer	1x Large Straight Door Retainer	1x Split Ring
				
1x Front Door	1x Base	1x Back Door	1x Upper Back Wall	1x Roof Support

				
2x Roof Clip	2x Nest Box End Wall	1x Nest Box Floor	1x Nest Box Front Wall	1x Nest Box Divider
				
1x Nest Box Roof	1x Ramp	1x Door Cord	1x Door Handle	1x Roof
				
2x Perch (Perch models only)	3x Vent Cover	23x Linch Pin (19 x on Non-Perch model)	2x Long Clevis Pin	1x Short Clevis Pin
				
2x Back Door Handle	1x Base Support			

DIMENSIONS

External Dimensions:
140 (w) x 78 (h) x 100 (d) cm (excluding ramp, including nest boxes)
Internal Floorspace:
91 (w) x 80 (d) cm (excluding nest boxes)

TOOLS REQUIRED

Sharp knife (e.g. Stanley Knife) or Sand Paper
Large size cross head screwdriver
10mm ring spanner (or socket wrench or adjustable spanner)
Small flat-bladed screwdriver (optional)

PRE-ASSEMBLY CHECKS

Prior to assembly, check that you have all the required parts. Please be aware that, being a recycled material, some minor surface blemishes or defects may have occurred during manufacture. These will not affect the functionality of your product.

Trim any excess plastic using sand paper or a sharp knife. **(NOTE: Be careful to cut away from yourself.)**

If any parts are missing, please email sales@greenfrogdesigns.co.uk

Please state the part number, quantity missing, your phone number and your full postal address.

SPARE PARTS

Spare parts are available to order online via our website: www.greenfrogdesigns.co.uk

HOW TO ASSEMBLE

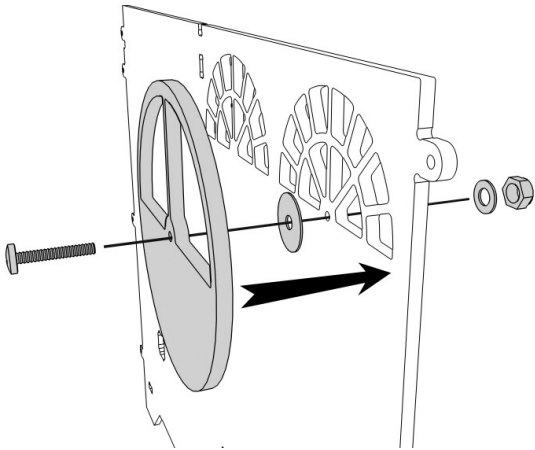
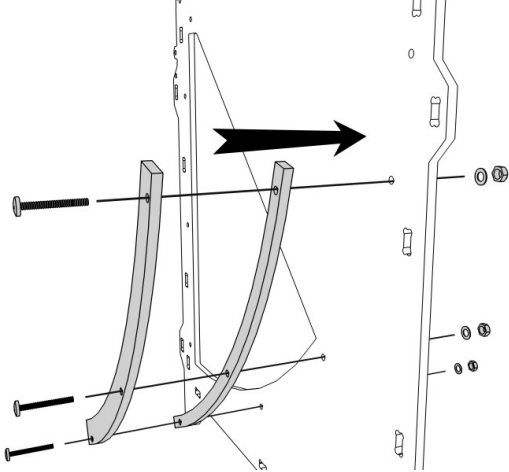
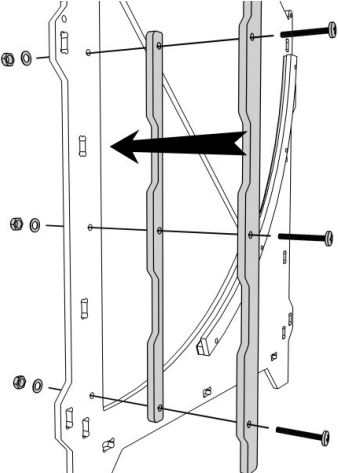
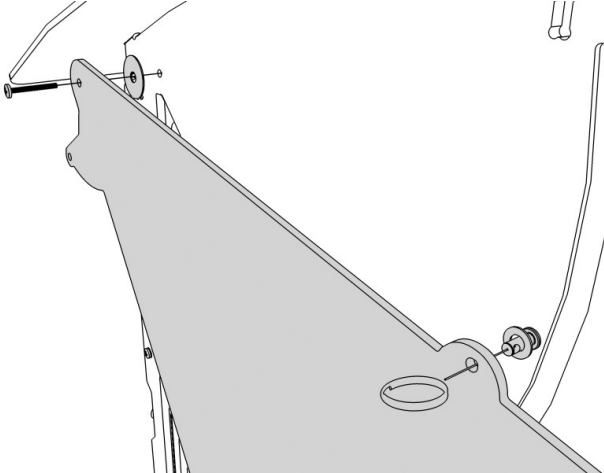
	
<p>1 Fit one Vent Cover to the gridded side of the Left Side Wall using an M6x30mm screw, a standard washer, a 25mm washer and a nylock nut (as shown in the diagram above). Tighten the nut until the vent can rotate using gentle pressure. It should not spin freely.</p> <p>Fit the other two vent covers to the Right Side Wall in the same way.</p> <p>The fourth vent does not have a cover, to ensure the chickens have some fresh air at all times.</p>	<p>2 Fit the Small Curved Door Retainer, followed by the Large Curved Door Retainer to the patterned side of the Front Wall using a M6x40mm Screws, Standard Washers, and Nylock Nuts. Make sure both Retainers have their patterned side outermost.</p> <p>Together, they form a curved recess within which the door will later rotate.</p>
	
<p>3 Fit Straight Door Retainers to the Front Wall in the same way. Ensure the smaller piece is sandwiched between the other two, and that the long straight edges face the doorway. Make sure both Retainers have their patterned side outermost.</p> <p>These pieces form a recess into which the door fits when closed, to help make the house resistant to fox attack.</p>	<p>4 Fit the Small Clevis Pin into the right hand hole in the Front Door from behind, and secure it using a washer and split ring. This can be a little awkward. We find that holding the split ring open by inserting a flat-bladed screwdriver between the rings can make this task easier. But please mind your fingers! Place the Front Door in position by sliding it between the retainers from the top, and secure it with a 30mm screw, a Standard Washer, a 25mm Washer and a Nylock Nut (Not visible in diagram). Tighten the Nylock Nut until the Front Door can just rotate freely.</p>

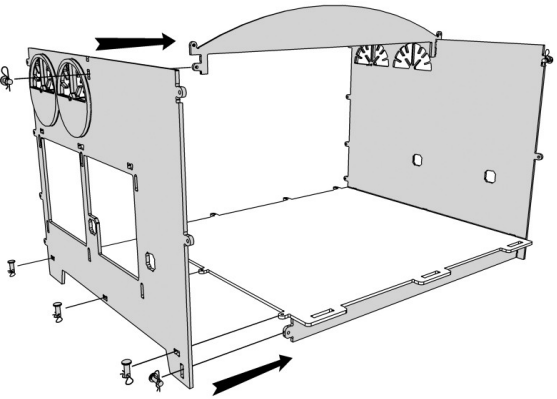
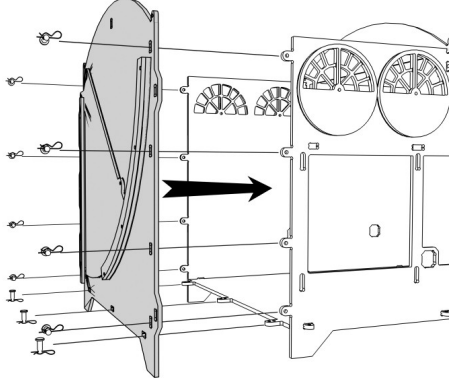
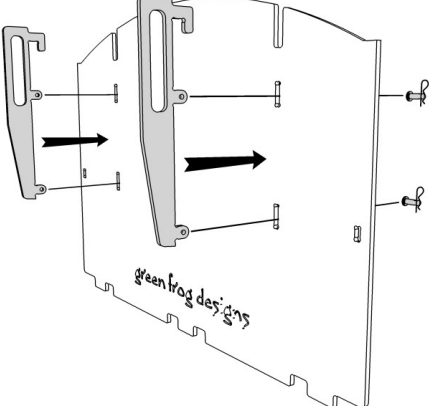
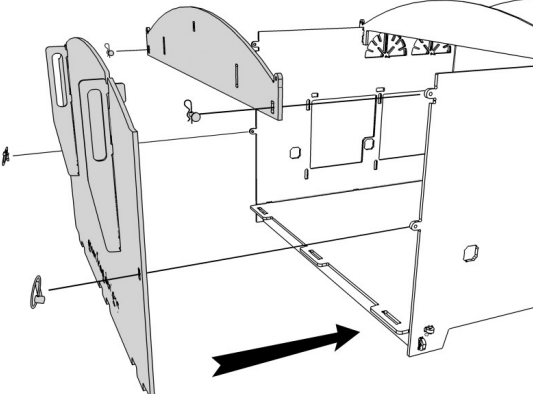
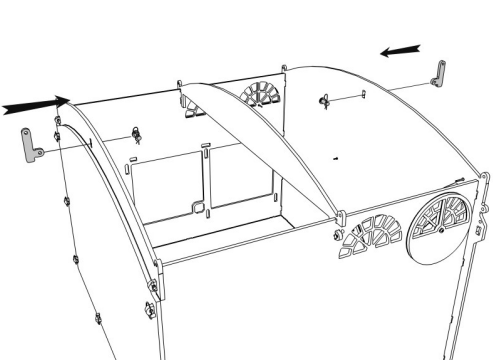
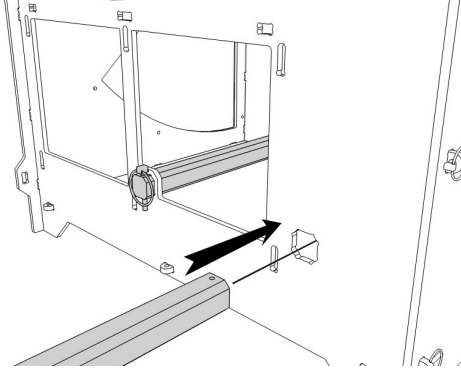
	
<p>5 Fit both Side Walls to the Base using Medium Clevis Pins and Retaining Clips (R-Clips). Ensure that the holes in the base, are situated as in the image above. Fit the Roof Support and Base Support between the two side walls.</p> <p>NOTE: The Base may be fitted either way up (smooth side or patterned side) as required. The smooth side is easier to clean, while the patterned side provides more grip, which may be important if you are housing chicks.</p>	<p>6 Fit the Front Wall (patterned face outermost) to the end of the Base with the double-hole lugs using Medium Clevis Pins and R-Clips.</p>
	
<p>7 Fit the Back Door Handles to the Back Door using Medium Clevis Pins and R-Clips.</p>	<p>8 Fit the Upper Back Wall using Medium Clevis Pins and then the Back Door using Linch Pins. (When fitting, rest the bottom of the Back Door in the slots in the Base first, push the door onto the lugs in the Side Walls, and slide the Back Door Handle downwards to lock the Back Door).</p>
	
<p>9 Fit Roof Clips to the Front Wall and Upper Back Wall using Medium Clevis Pins and R-Clips.</p>	<p>10 (Note: Skip this step for non-perch models) Slide the Perches through the Left and Right Side Walls and secure with Linch Pins at both ends.</p>

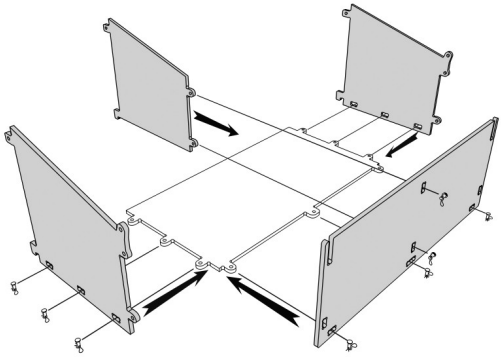
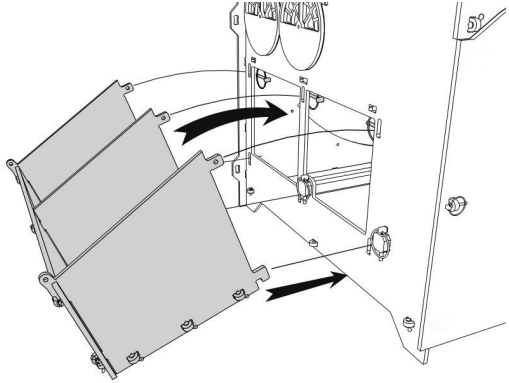
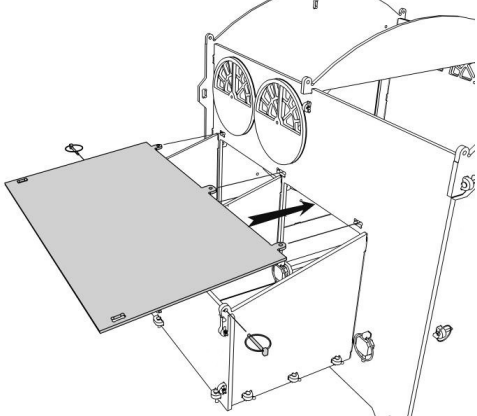
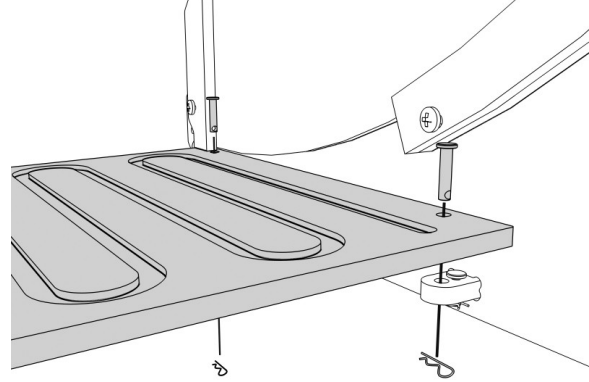
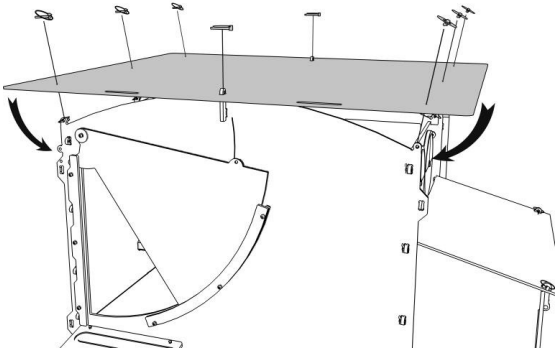
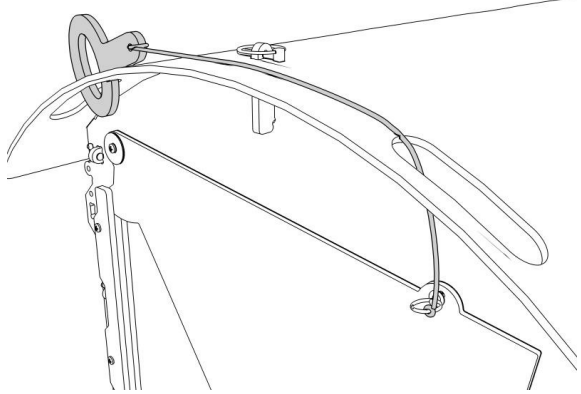
	
<p>11 Fit the Nest box End Walls to the Nest Box Floor using Medium Clevis Pins and R-Clips. Fit the Nest Box Front Wall to the Nest Box Floor and End Walls using Medium Clevis Pins and R-Clips. Fit the Nest Box Divider to the Nest Box Floor and Front Wall using Medium Clevis Pins and R-Clips.</p>	<p>12 Fit the nest box to the house by first inserting the L-lugs into the lower holes on the Right Side Wall, then tilting the nest box to push the three upper lugs through their holes, before securing them inside the main house with Linch Pins.</p>
	
<p>13 Fit the Nest Box Roof by pushing its lugs through the holes in the Right Side Wall and secure it with Linch Pins (not shown) inside the main house. Two Linch Pins are used to secure the nest box lid – these can be quickly removed for daily access.</p>	<p>14 Fit the Ramp under the door using the two Long Clevis Pins and R-Clips. It will tilt to the ground under its own weight.</p>
	
<p>15 Fit the Roof using Linch Pins. Fix the centre first, then bend the sides down over the remaining lugs.</p>	<p>16 Tie one end of the Door Cord to the Split Ring in the Front Door and the other to the small hole in the Door Handle. The Cord should pass through the handhold. Adjust the length so that, when the door is fully raised, the slot in the handle just hooks onto the edge of the opposite handhold.</p>

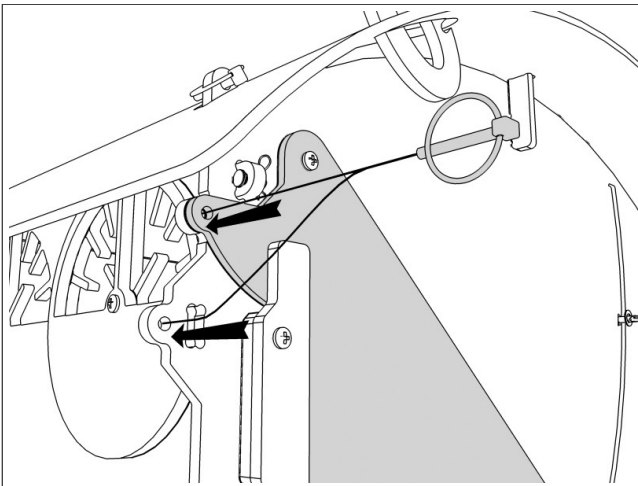

17 The **Front Door** can be fixed in the closed position by inserting a quick release **Linch Pin** here. When not in use it can be fitted in the spare hole as indicated above.

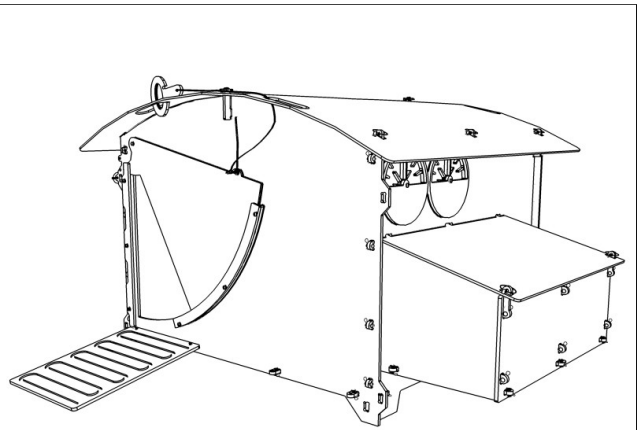

18 You're finished - Have a cup of tea!

INSTRUCTIONS FOR USE

The house should be sited in a sheltered area with the front facing away from prevailing winds. Vents should be adjusted to provide adequate ventilation. At least one hole should always be open.

The rear door can be used for inspection, and regular cleaning. For thorough cleaning and replacing of bedding, the entire roof can be removed.

This chicken house is designed to be moved by two people, using the handholds cut into the roof.

We recommend thorough cleaning at least every 3 months – a pressure washer is ideal for removal of caked on dirt, but an ordinary hosepipe and scrubbing brush will do. The plastic is quite easy to clean. Finish by applying Poultry Shield (or similar) and leave to dry.