

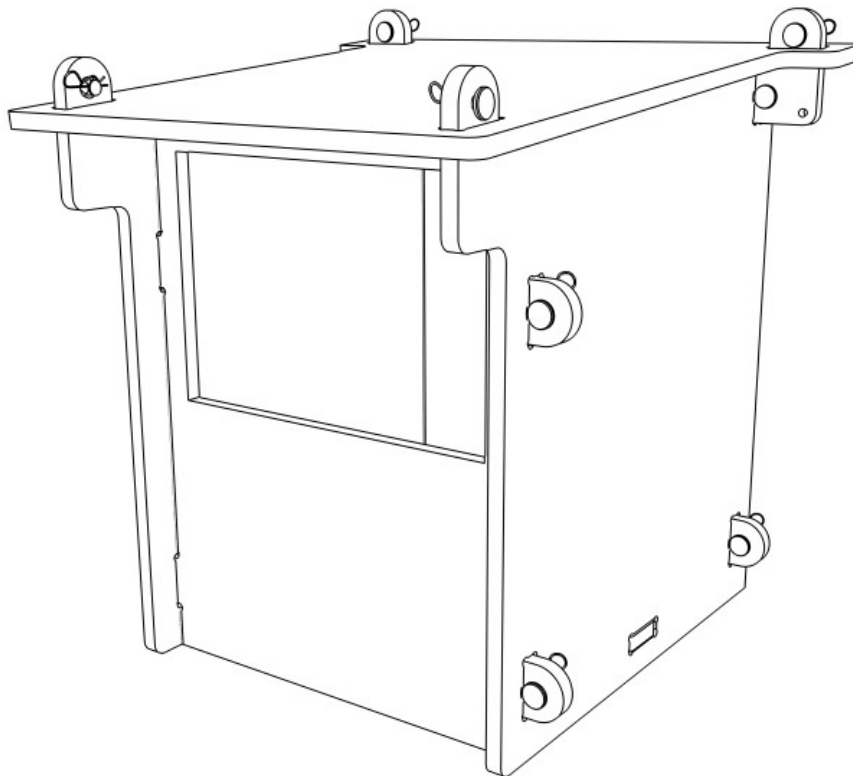

## HOW TO ASSEMBLE, USE AND CARE FOR YOUR Square Entrance Bird House



## RECYCLED & RECYCLABLE

Products from green frog designs are made, wherever possible, from materials that are recycled. Where this is not practical, we always try to use materials that are suitable for recycling.

Our plastic is made from recycled waste plastic, predominantly plastic wrapping and carrier bags. By choosing our products, rather than those made from virgin plastic, you are helping to restrict the amount of new plastic being made. We recycle all our waste plastic and, of course, our products themselves can be recycled (if they ever wear out!!).

The recycled plastic we use is incredibly tough, but is as easily worked as wood. There is no need for preservative treatment with insecticides or fungicides, and structures won't splinter or crack, so they retain their structural integrity well. The plastic is resistant to UV light, so it retains its colour well, and is pretty much impervious to atmospheric pollutants and seasonal climatic actions such as freeze-thaw. It insulates quite well, and is also resistant to chewing. These properties mean that it retains its appearance, colour and functionality for much longer than timber.

The sheets of recycled plastic have a very uniform thickness, and so are ideally suited to our high-technology manufacturing process, which uses computer-controlled machines to cut shapes to accuracies better than 0.1mm.

We also use some metal components to fix parts together. The metals used are either stainless steel or other rust-resistant alloy, so they have a very long lifetime. They are also suitable for recycling.

Our packaging and literature is all made from recycled materials wherever possible. For example, assembly instructions are printed on recycled paper, and we use recycled plastic bubble-wrap in our packaging. Even our business cards are made from 80% recycled card.

In other words: **Fun, functional products that don't cost the Earth!**



### HOW TO FIT A CLEVIS PIN (IF USED)

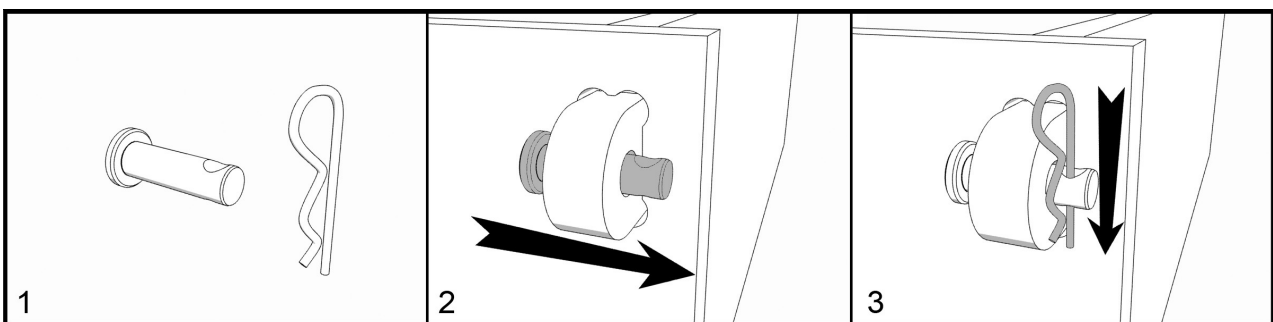



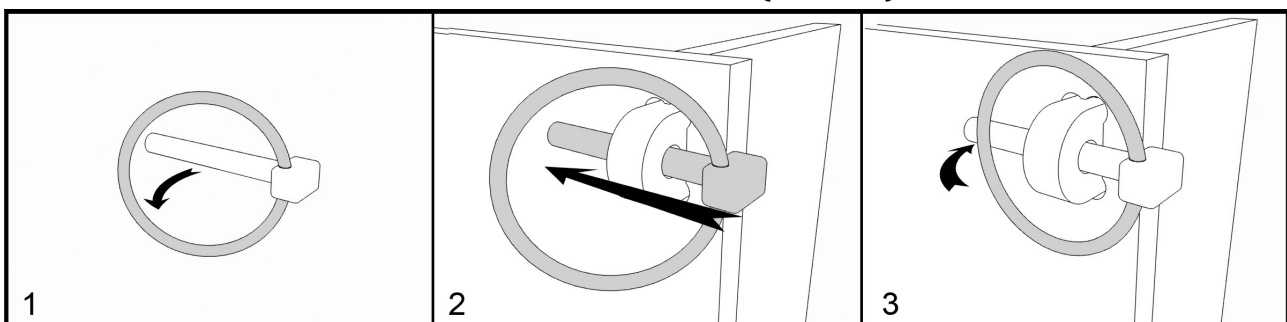

### HOW TO FIT A LINCH PIN (IF USED)

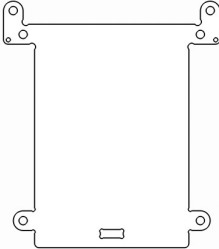
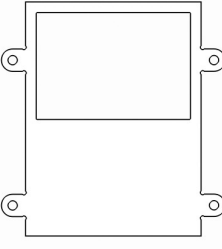
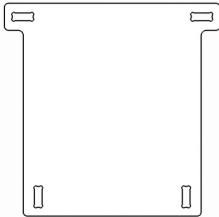
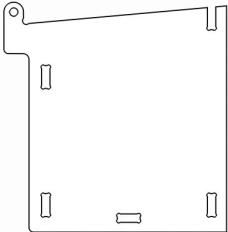
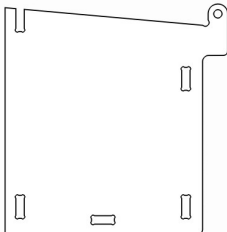

Linch Pins are designed to spring closed, so watch your fingers!

## PARTS

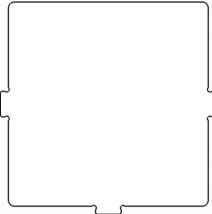
									
<b>12x</b>	Short Clevis Pin	<b>12x</b>	R-Clip	<b>1x</b>	Back Panel	<b>1x</b>	Front Panel	<b>1x</b>	Roof
									
<b>1x</b>	Right Side Panel	<b>1x</b>	Left Side Panel	<b>2x</b>	Steel Screw	<b>1x</b>	Floor		

## DIMENSIONS

Dimensions: 23 (w) x 23 (h) x 23 (d) cm

## TOOLS REQUIRED

Sharp knife (e.g. Stanley Knife) or Sand Paper  
Medium size cross head screwdriver

## PRE-ASSEMBLY CHECKS

Prior to assembly, check that you have all the required parts. Please be aware that, being a recycled material, some minor surface blemishes or defects may have occurred during manufacture. These will not affect the functionality of your product.

Trim any excess plastic using sand paper or a sharp knife. **[NOTE: Be careful to cut away from yourself.]**

If any parts are missing, please email [sales@greenfrogdesigns.co.uk](mailto:sales@greenfrogdesigns.co.uk)

Please state the part number, quantity missing, your phone number and your full postal address.

## SPARE PARTS

Spare parts are available to order online via our website: [www.greenfrogdesigns.co.uk](http://www.greenfrogdesigns.co.uk)

## HOW TO ASSEMBLE

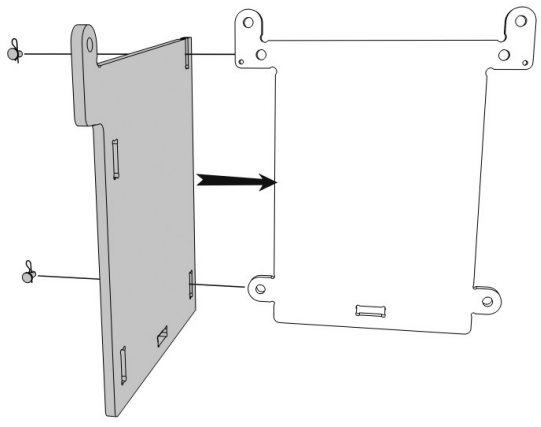
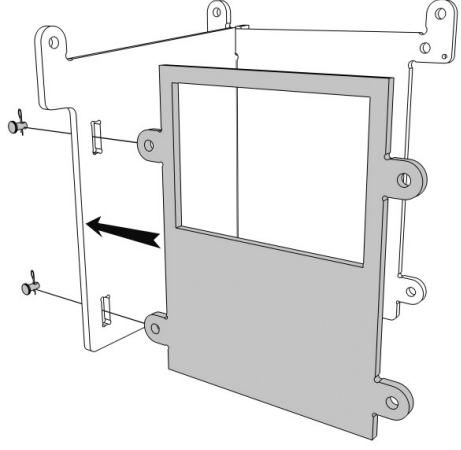
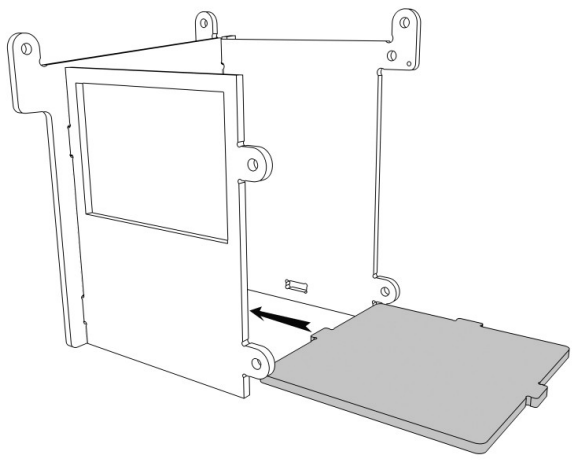
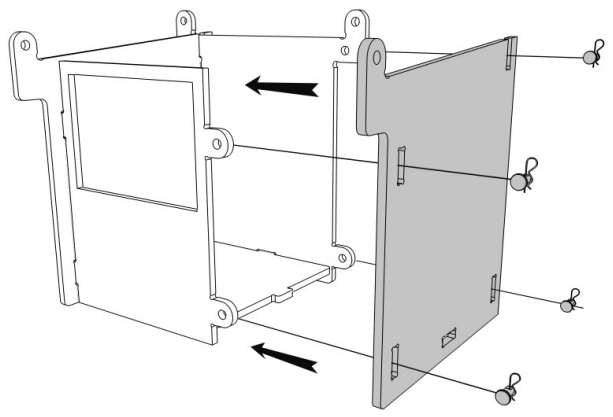
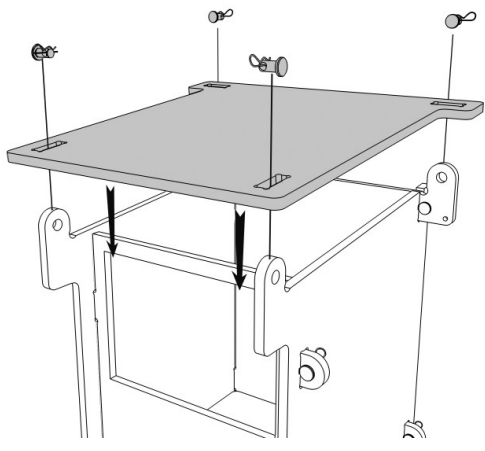
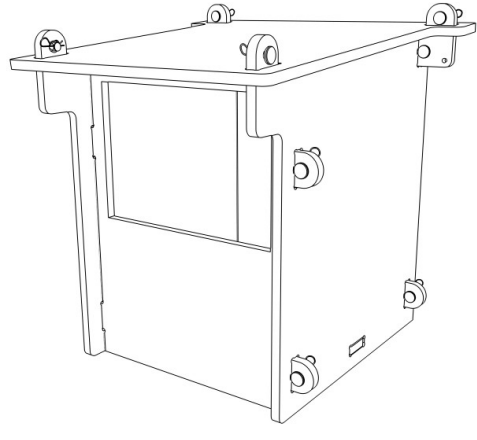
	
<p><b>1</b> Fit the <b>Left Side Panel</b> onto the <b>Back Panel</b> with pattern outermost on both. Secure in place using 2 <b>Clevis Pins</b> and <b>R-Clips</b> (see above).</p>	<p><b>2</b> Slide the <b>Front Panel</b> onto the <b>Left Side Panel</b> and secure with <b>Clevis Pins</b> and <b>R-Clips</b>.</p>
	
<p><b>3</b> Slide the <b>Floor</b> into place, with the non-tabbed edge to the front.</p>	<p><b>4</b> Fit the <b>Right Side Panel</b> onto the assembly, to hold the <b>Floor</b> in place. Secure with <b>Clevis Pins</b> and <b>R-Clips</b>.</p>
	
<p><b>5</b> Fit the <b>Roof</b> and secure with <b>Clevis Pins</b> and <b>R-Clips</b>.</p>	<p><b>6</b> Finished! The upper rear lugs have two small holes that can be used to secure the house to a post, wall etc. using screws. Alternatively, you can use rot-proof string to tie the box to a tree or post.</p>